

- ▶ High-strength, long-lasting steel body
- ▶ Extra reinforced planetary gear system with special steel heat treatment
- ▶ Lightweight and powerful design
- ▶ 100% negative effective hydraulic disc brake system
- ▶ Standard winch guide system and rope stabiliser
- ▶ Manual winch discharge system provided as standard
- ▶ High torque hydromotor

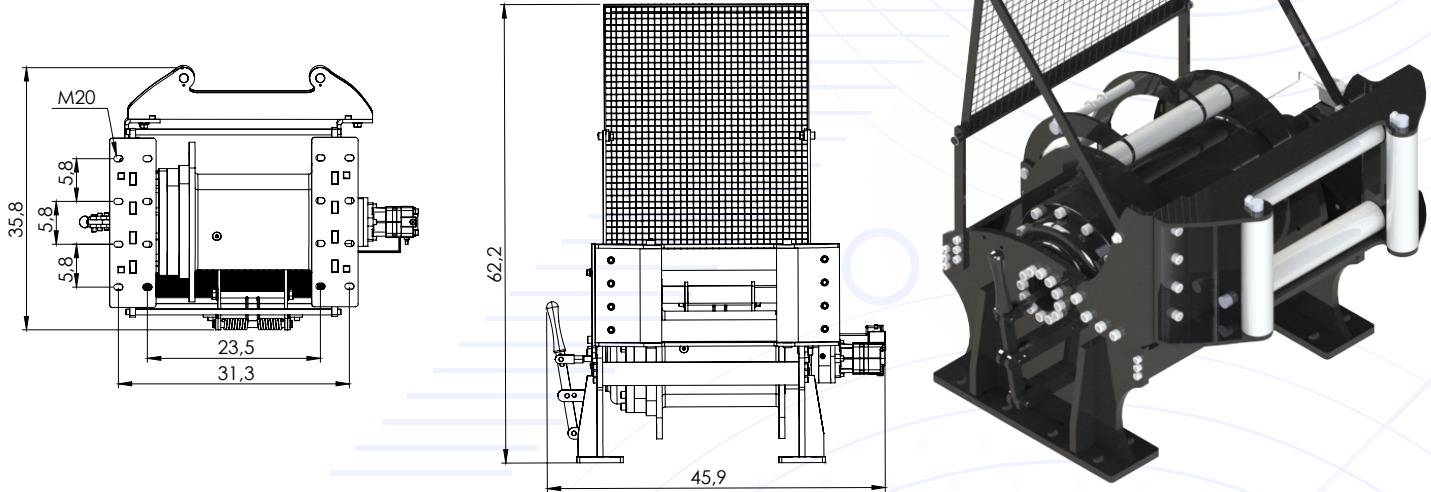

Rope Winding Count	Pulling Capacity lbs	Winding Speed m-min/(ft-min)	Rope Length m/ft
1	66000	3,5/11	16,6/54
2	58047	3,9/12	34,5/113
3	51482	4,5/14	53,5/175
4	45252	5/16	74/242

Maximum Pulling Force (kg/lbs)	: 66000 lbs
Maximum Rope Diameter (mm/in)	: 26mm (1")
Maximum Rope Length (m/ft)	: 74 m (242 ft)
Hydromotor (cc/in <sup>3</sup> )	: 160 cc (9,6 in <sup>3</sup> )
Maximum Pump Flow (L/min-g min)	: 75L (19.8 gal)
Gear Ratio	: 150/1
Maximum Operating Pressure (bar/psi)	: 165 bar (2393 psi)
Recommended Gear Oil Product	: 80w 90 - 4L (135.2 fl oz)
Weight	: 485 kg (1069 lbs)