

- ▶ High-strength, long-lasting steel body
- ▶ Extra reinforced planetary gear system with special steel heat treatment
- ▶ Lightweight and powerful design
- ▶ 100% negative effective hydraulic disc brake system
- ▶ Standard winch guide system and rope stabiliser
- ▶ Manual winch discharge system provided as standard
- ▶ High torque hydromotor

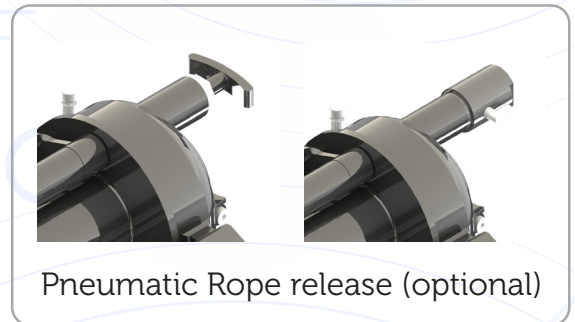
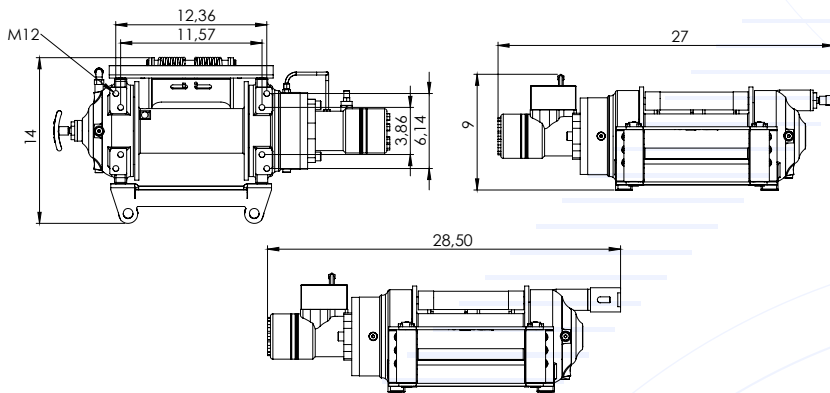
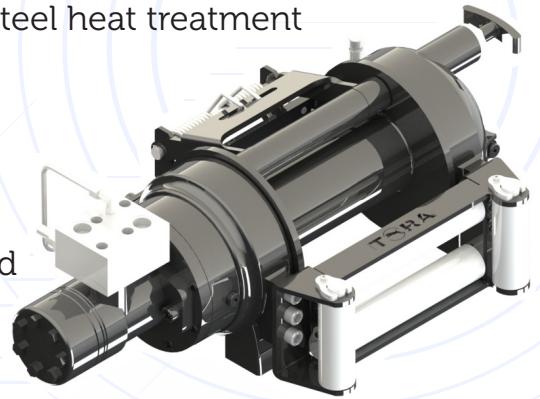

Rope Winding Count	Pulling Capacity lbs	Winding Speed m-min/(ft-min)	Rope Length m/ft
1	8000	17,9/58	6,85/22
2	6700	19,8/64	14,4/47
3	5776	21,7/71	22,6/74
4	5070	23,6/77	31,5/103
5	4523	25,5/83	41/134

Maximum Pulling Force (kg/lbs)	: 8000 lbs
Maximum Rope Diameter (mm/in)	: 10mm (3/8")
Maximum Rope Length (m/ft)	: 41 m (134 ft)
Hydromotor (cc/in <sup>3</sup> )	: 200 cc (12 in <sup>3</sup> )
Maximum Pump Flow (L/min-g/min)	: 60L (15.8 gal)
Gear Ratio	: 5/1
Maximum Operating Pressure (bar/psi)	: 120 bar (1740 psi)
Recommended Gear Oil Product	: 80w 90 - 0.70L (23.6 fl oz)
Weight	: 63 kg (138 lbs)