

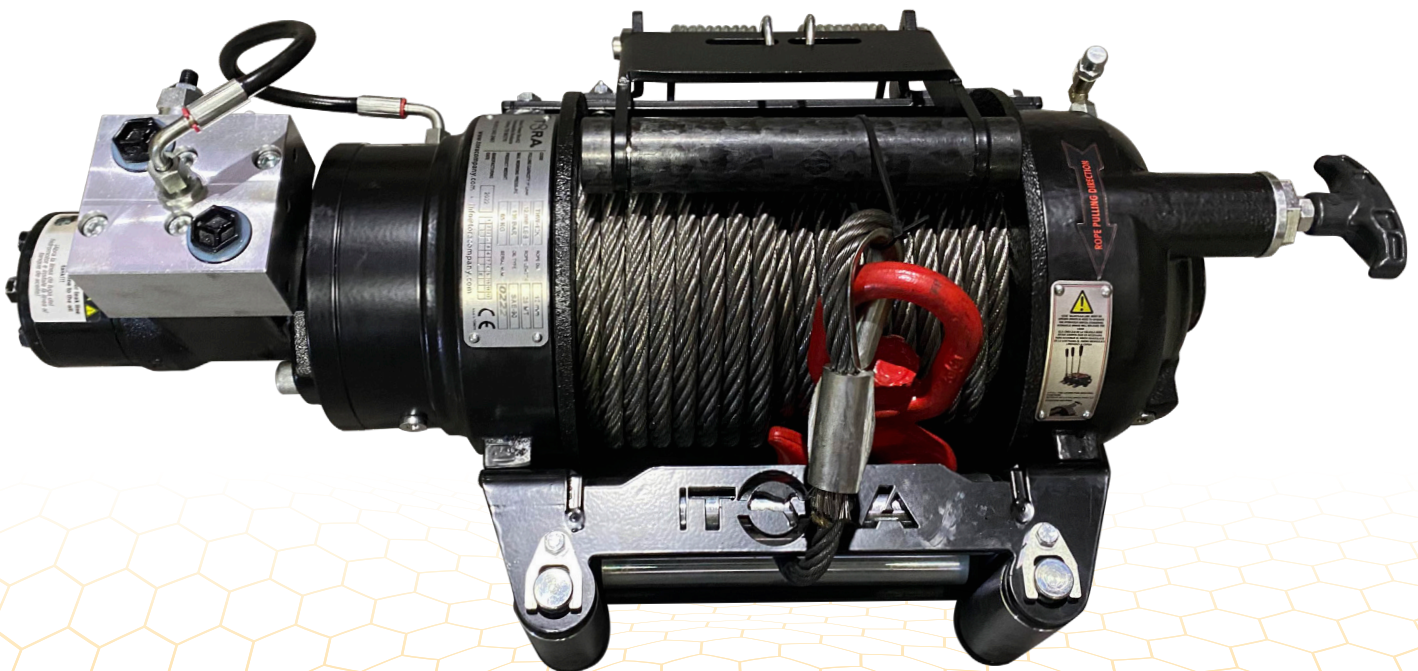

# HYDRAULIC WINCH USER AND SERVICE MANUAL



[www.toracompany.com](http://www.toracompany.com)

**PLEASE BE SURE TO READ THIS MANUAL CAREFULLY  
BEFORE STARTING TO USE THE HYDRAULIC WINCH!**

<b>3</b>	INTRODUCTION
<b>3</b>	SAFETY INSTRUCTIONS
<b>6</b>	GENERAL LOAD PULLING RULES
<b>8</b>	GENERAL ASSEMBLY INSTRUCTIONS
<b>9</b>	HYDRAULIC SYSTEM ASSEMBLY
<b>10</b>	ROPE ASSEMBLY
<b>11</b>	GENERAL USER INSTRUCTIONS
<b>12</b>	USE OF EMPTY-LOADED LEVER
<b>13</b>	USE OF PNEUMATIC EMPTY-LOADED LEVER
<b>14</b>	LOAD PULLING PROCESS
<b>16</b>	GENERAL MAINTENANCE
<b>17</b>	PROBLEM – CAUSE – SOLUTION TABLE
<b>19</b>	POINTS TO CONSIDER WITH REGARDS TO ROPE
<b>20</b>	WARRANTY TERMS AND WARRANT CERTIFICATE
<b>21</b>	CERTIFICATES

## INTRODUCTION

This Hydraulic winch has been manufactured solely for load pulling purposes within the specified capacity range. Do not use it for lifting.

## ABOUT THE MANUAL

This user and service manual comprises of general maintenance and user instructions for the Hydraulic winchs, of which brand is "TORACO". Be sure to read this manual carefully before starting to use the Hydraulic winch. Follow the maintenance and safety instructions in this manual in order for a safe and long life-cycle. Where you encounter a situation that is not addressed in this manual, please contact to representative of "TORACO".

## SAFETY INSTRUCTIONS



### **WARNING!!!**

**PLEASE READ AND FOLLOW ALL THE SAFETY INSTRUCTIONS IN ORDER TO PREVENT THE ACCIDENTS AND INJURIES!**

- ▶ Do not start using any controlling and usage apparatus before getting familiar with them.
- ▶ Keep this manual in a safe place for general maintenance instructions.
- ▶ Rupture of the rope or an unexpected movement of the load may lead to fatal accidents. Therefore, be sure to keep the working area clear of any people.
- ▶ Do not use the empty-loaded lever when the Hydraulic winch is under load.
- ▶ Otherwise, it may lead the load to loose and also to accidents.
- ▶ When the drum is under load, do not control it with sudden movements.
- ▶ Otherwise, it may lead the drum to be damaged or to accidents.
- ▶ Keep away from moving parts, moving rope and load.

- ▶ Be sure that the operating site and the surrounding area of the load is clean before starting the pulling process.
- ▶ Do not use the Hydraulic winch under the influence of alcohol and drugs.
- ▶ Use the accessories and spare parts that are recommended by the manufacturer only.
- ▶ In case of detecting any noise or vibration out of the Hydraulic winch, cease the operation immediately and check the system.
- ▶ Do not use the Hydraulic winch for any other purposes than those designated for it.
- ▶ Do not try to hoist loads that exceed the capacity of the Hydraulic winch.
- ▶ Do not try to hoist the load from right side or left side of the Hydraulic winch under no circumstances. Use the steering tackle where deemed required.
- ▶ Keep the pulling route clear of any obstacles.
- ▶ Take any and all the conditions such as the elevation, surface texture, load state (wheeled, draggable, etc.) into consideration before starting the operation.
- ▶ Always fix the rope to a sturdy point of the load.
- ▶ Be sure to wear all the protective personal equipment such as gloves, helmet, iron-tipped shoes etc., before starting the operation.
- ▶ Check the anchor bolts, hydraulic connections and the rope of the Hydraulic winch before starting the operation.
- ▶ Change the rope of the drum if it is damaged.

It is a must to keep the last five (5) windings over the Hydraulic winch.



Be sure to keep a safe distance from the operation site, in that the rope may rupture, thus leading to fatal accidents.



Under no circumstances should you lift people with the Hydraulic winch!



Wear the protective goggles.



Always wear the helmet.



Always wear the gloves.



Always wear the iron-tipped protective shoes.

## Pulling Angle

Hoist the load with a maximum of 15o angle (horizontally) in order to ensure a long life-cycle for the rope. Where the pulling is performed from vertical angles, the rope will not properly wind to the drum, thus getting damaged.

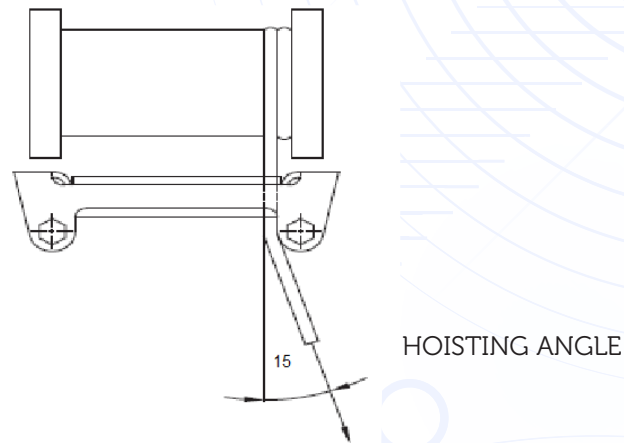

## Pulling Capacity

The Hydraulic winchs are always categorized based on the pulling capacity on the lowermost winding of the drum. Therefore, take this detail into consideration when deciding to buy a drum. The hoisting capacity and speed change based on the number of rope winding. The drum has the highest hoisting capacity and lowest hoisting speed on the lowermost winding. On the other hand, the drum has the lowest pulling capacity and highest winding speed on the upmost winding.

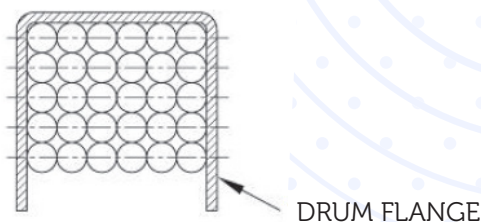
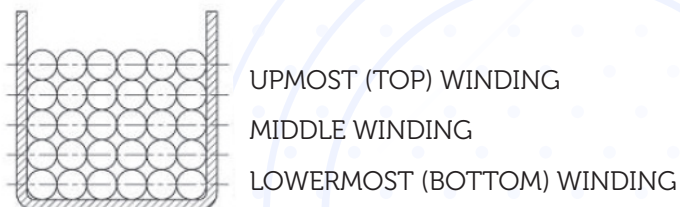

**The Required Pulling Force**

In addition to the weight of the load, factors such as the slope and the surface texture may increase the weight of the same while pulling the load. The surface texture may be categorized as mud, sullage, sand or gravel. Therefore, you can find the required pulling force using the following calculation methods and tables through these factors before starting the pulling process.

$$RPF = (Wt \times S) + (Wt \times G)$$

RPF: Required Pulling Force

Wt: Weight of the load

S: Ground based surface friction coefficient

G: Slope coefficient

For example, the required pulling force can be calculated as follows for a 3000 kg of vehicle with a slope ratio of 100%, as stuck to sullage:

Wt: 3,000 kg, S: 0.625, G: 0.71

Surface Type	Friction Coefficient (S)
ASPHALT	0,050
GRASS	0,175
GRAVEL	0,250
SAND	0,325
MUD	0,425
SULLAGE	0,625

SLOPE %	Angle (°)	Slope Coefficient (G)
5	30	0,06
10	60	0,11
20	110	0,2
30	170	0,3
50	260	0,44
70	350	0,58
100	450	0,71

$$RPF = (Wt \times S) + (Wt \times G)$$

$$= (3,000 \text{ kg} \times 0.625) + (3,000 \text{ kg} \times 0.71)$$

$$= 1,875 \text{ kg} + 2,130 \text{ kg}$$

$$= 4,005 \text{ kg Required pulling force}$$

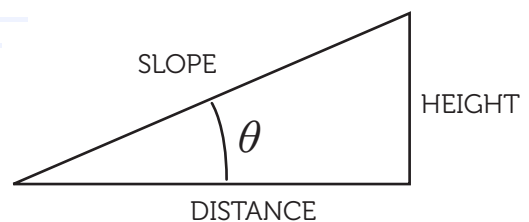

The Hydraulic winch can be assembled to a vehicles shown as follows. While assembling the Hydraulic winch, be sure to follow the technical instructions specified in this manual for safe use.

The assembly is made on a flat metal sheet. The thickness of the metal sheet on which the Hydraulic winch is planned to be assembled must be at least 10-12mm (For THW-8K, THW-10K, THW-12K, THW-15K, THW-16K, THW-18K Series)

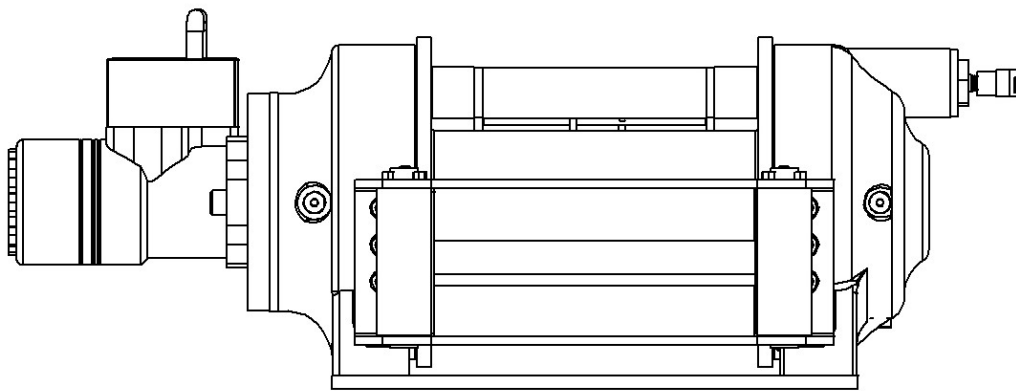

The assembly is made on a flat metal sheet. The thickness of the metal sheet on which the Hydraulic winch is planned to be assembled must be at least 15mm (For TORAco THW-22K, TORAco THW-26K, TORAco THW-33K Series)

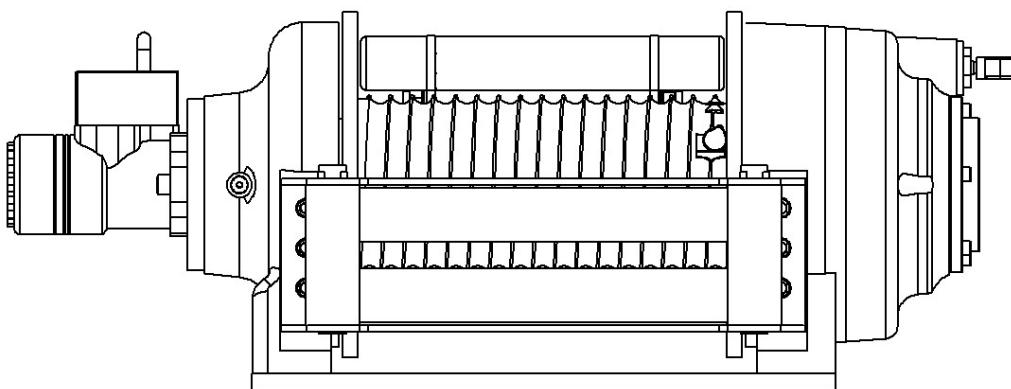



**Hydraulic system assembly**

You can assemble the hydraulic connections as shown on the following drawings based on the rope winding style.

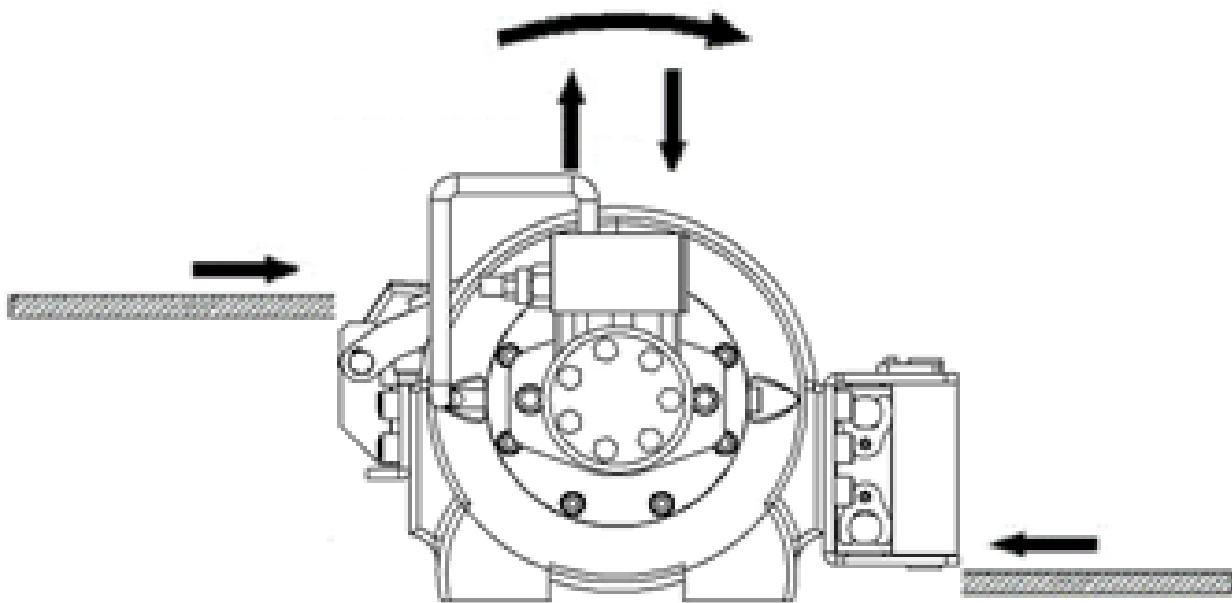

For TORAco THW-8K, TORAco THW-10K, TORAco THW-12K, TORAco THW-15K, TORAco THW-16K, TORAco THW-18K, TORAco THW-22K, TORAco THW-26K, TORAco THW-33K models.

## Rope assembly

The rope assembly is based on the area where the Hydraulic winch is planned to be mounted.

- Where you plan to mount the Hydraulic winch on a metal sheet with a frontal pulley, you must assemble the rope as shown in the drawing, and fix the rope passing under the Hydraulic winch.

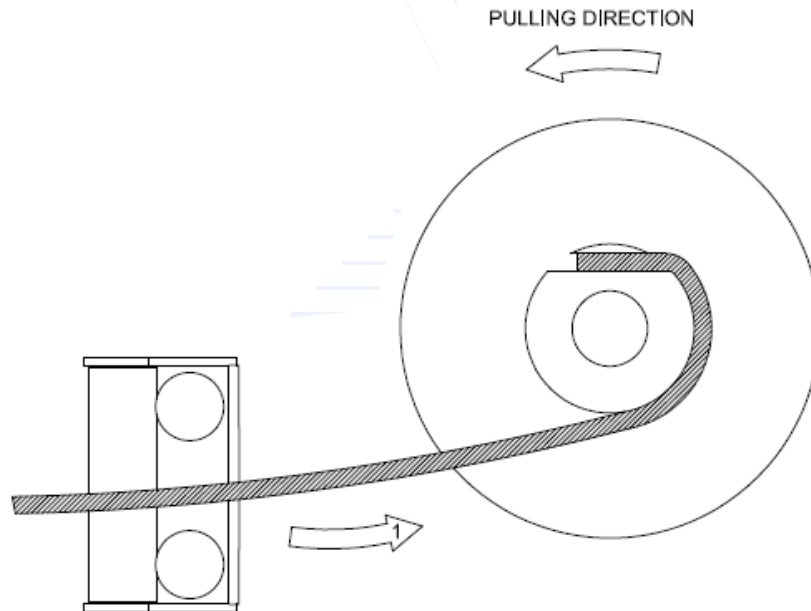

- If you mounted the Hydraulic winch using a bracket, the rope must be assembled as shown in the drawing.

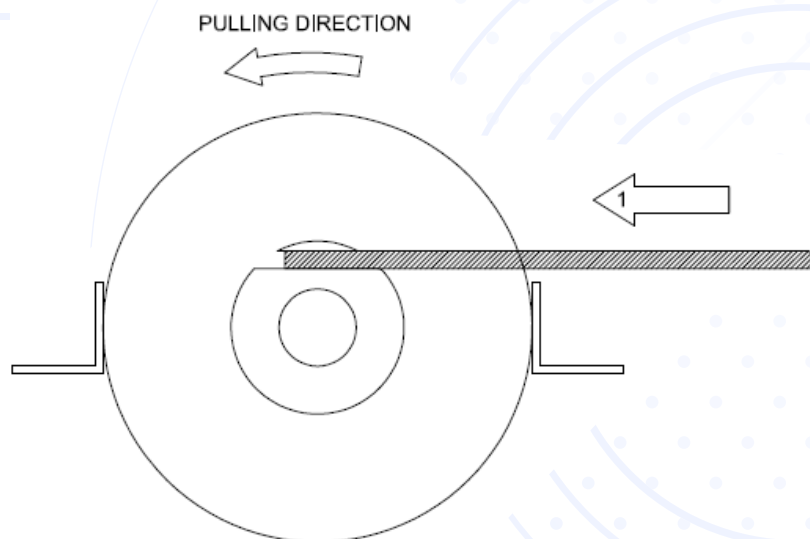

**ALWAYS CHECK THE ROPE FIXING BOLT. LOOSE BOLTS MAY LEAD THE ROPE TO DISPLACE, THUS CAUSING SERIOUS ACCIDENTS.**

**GENERAL**

This technical drawing is for TORAcO THW-8K, TORAcO THW-10K, TORAcO THW-12K, TORAcO THW-15K, TORAcO THW-16K, TORAcO THW-18K models.

- 1- Manual or Pneumatic empty-loaded lever
- 2- Gearbox oil filler plug
- 3- Rope pressure pulley
- 4- Drum (pulley)
- 5- Brake body
- 6- Brake valve
- 7- Hydro-motor
- 8- Brake cap
- 9- Frontal quad steering pulley
- 10- Oil level controlling plug
- 11-Transmission body (gearbox)

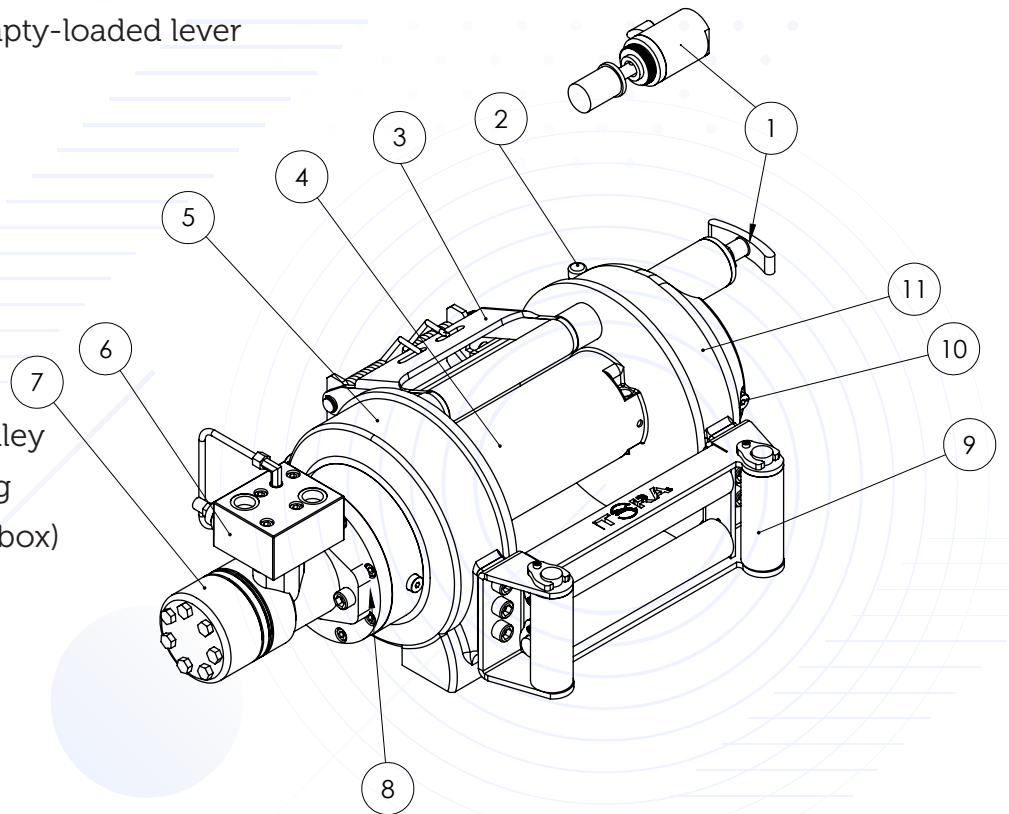

**CHECK THE FOLLOWING BEFORE STARTING THE PULLING OPERATION!**

- Check all the hydraulic connection points for loose parts and leakages.
- Check if the rope is damaged.
- Check the hydraulic oil level from the oil tank.
- Make sure that there is no one present in the operation site.

**Follow the following process to release a rope manually:**

Pull the empty-loaded lever towards yourself as shown in the drawing with a 90° angle and leave it there. The manual rope release lock is opened this way. Then, you can manually pull the rope towards the load.

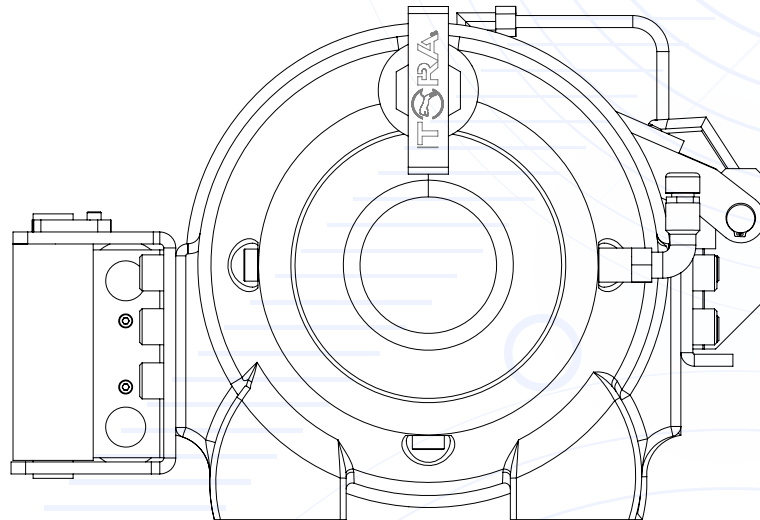

**THE LAST FIVE (5) ROPE WINDING MUST BE LEFT OVER THE DRUM!**

**Follow the following process in order to take the Hydraulic winch to the pulling position:**

Position the empty-loaded level as shown in the drawing. This will ensure the Hydraulic winch to be locked. Then, you can start the pulling process by providing power to the Hydraulic winch through the hydraulic controlling levers.

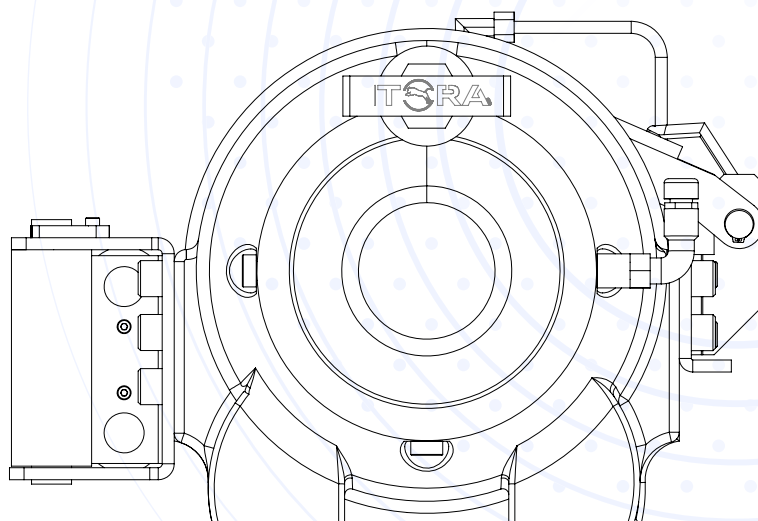

This technical drawing is for TORAco THW-22K, TORAco THW-26K, TORAco THW-33K series.

- 1- Manual or Pneumatic empty-loaded lever
- 2- Gear box oil filling plug
- 3- Rope pressure pulley
- 4- Drum (pulley)
- 5- Brake body
- 6- Brake valve
- 7- Hydro-motor
- 8- Brake cap
- 9- Frontal quad steering pulley
- 10- Oil level controlling plug
- 11- Transmission body (gearbox)

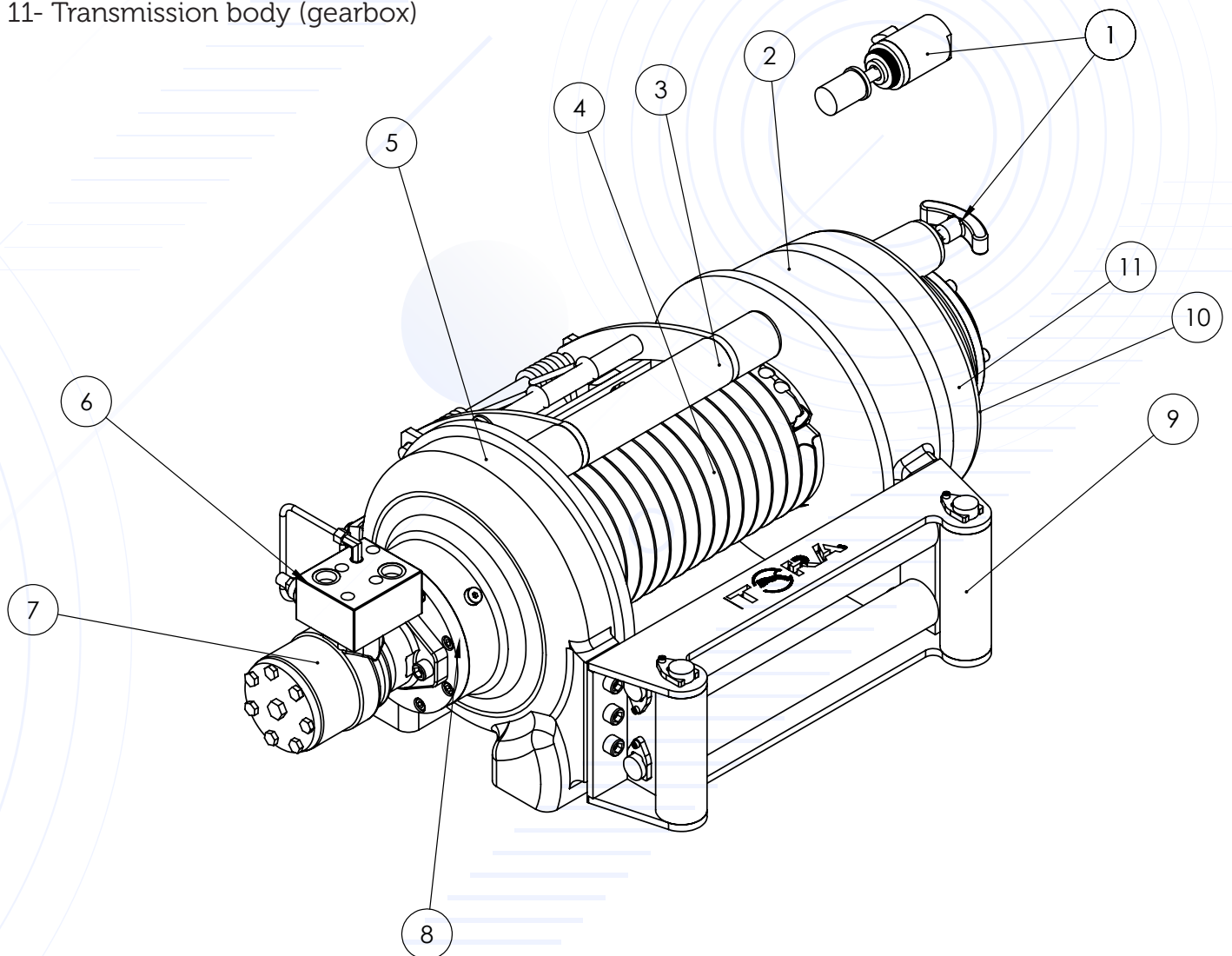

### USE OF PNEUMATIC EMPTY-LOADED LEVER

**Follow the following process in order to release the manual rope pneumatically:**

Apply pressurized air on the coupling over P point.

**Follow the following process in order to take it to the pneumatic load pulling position:**

Cease the pressurized air applied on the coupling over P point.

### LOAD PULLING PROCESS



Please follow the following instructions and rules during the pulling process:

- ▶ Avoid sudden movements during the pulling process and start the operation by slowly pushing the controlling lever.
- ▶ Make sure that there is no one present in the operation site.
- ▶ Do not try to pull loads that exceed the capacity of the Hydraulic winch. Place the vehicle on a certain line with the Hydraulic winch before starting the pulling process.

Place the vehicle on a certain line with the Hydraulic winch before starting the pulling process.

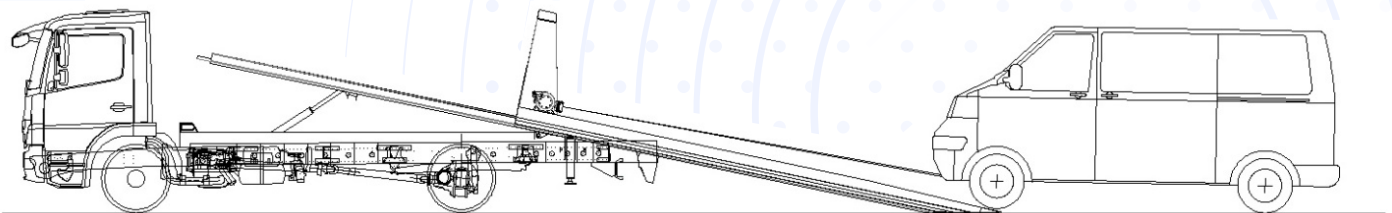

Where this is not possible, direct the rope towards the load with the help of the pulley and tackle as can be seen in the drawing.

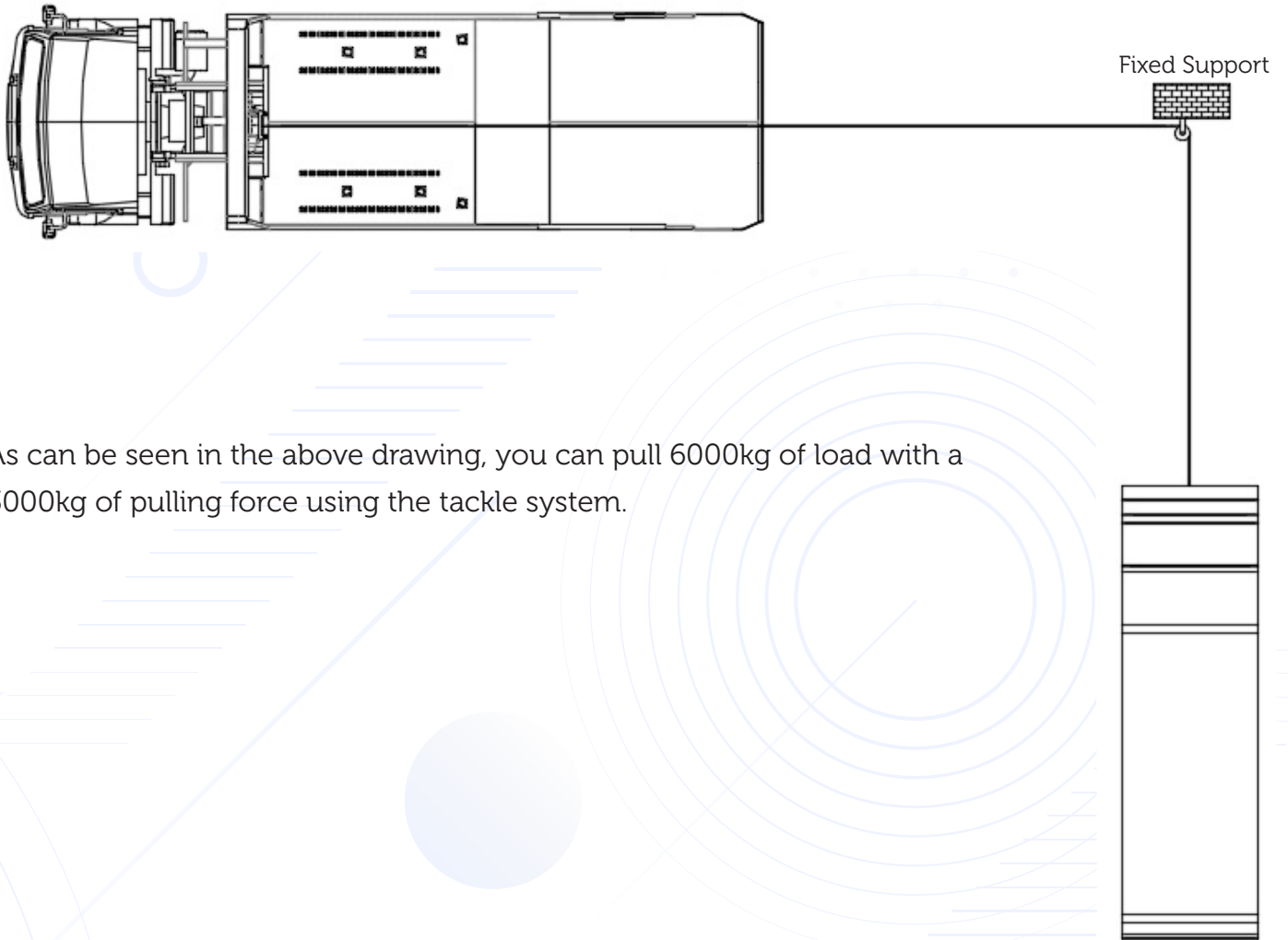

As can be seen in the above drawing, you can pull 6000kg of load with a 3000kg of pulling force using the tackle system.

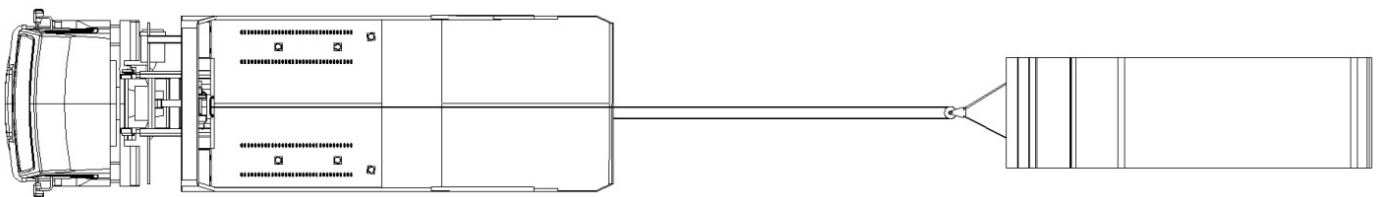

Please read the general maintenance instructions and rules given in this manual for a safe and longer life-cycle. Otherwise, the Hydraulic winch may be damaged, thus leading accidents.



THE OIL CHANGING PROCESS SHOULD BE DONE ONCE IN CHANGING THE LUBRICATION OIL

FOR TORAco THW-8K Small, TORAco THW-10K Small, TORAco THW-12K Small, TORAco THW-15K Large, TORAco THW-16K, TORAco THW-18K Models

- ▶ First, open the gear box oil filling plug, which is numbered as 1.
- ▶ Then open the oil discharge plug, which is numbered as 3, and discharge the oil to a container.
- ▶ After discharging all the oil, close the oil discharge plug and dismantle the oil level plug, which is numbered as 2.
- ▶ Fill up the gearbox oil with a quality SAE-80 until the up to oil level plug, and close down the plug.
- ▶ Finish the process by closing the gearbox oil filling plug (plug no.: 1).

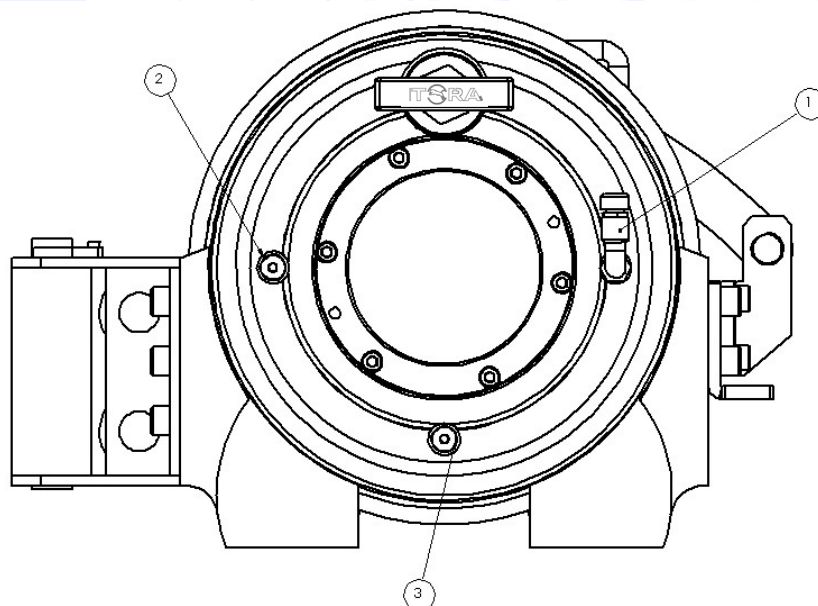

THE OIL CHANGING PROCESS SHOULD BE DONE ONCE IN EVERY TWO YEARS!







PROBLEM	CAUSE	SOLUTION
<p><b>The Hydraulic winch is not working.</b></p>	<p>No oil flow rate</p>	<ul style="list-style-type: none"> <li>• Check the hydraulic oil level.</li> <li>• Check all the hydraulic fitting and the components against leakages and congestions.</li> </ul>
	<p>Hydraulic brake does not release.</p>	<ul style="list-style-type: none"> <li>• Check the pressure on the brake input. (min. 40bar)</li> <li>• Check the brake valve for any contamination. If contaminated, clean it up.</li> <li>• Check the brake hose.</li> </ul>
	<p>PTO is not ON</p>	<ul style="list-style-type: none"> <li>• Put the PTO into use.</li> </ul>
	<p>Damaged hydromotor</p>	<ul style="list-style-type: none"> <li>• Change the hydromotor</li> </ul>
	<p>Damaged pump</p>	<ul style="list-style-type: none"> <li>• Change the pump</li> </ul>
	<p>Damaged hydraulic fitting</p>	<ul style="list-style-type: none"> <li>• Change the damaged part</li> </ul>

PROBLEM	CAUSE	SOLUTION
<b>Hosting drum (pulley) is not rotating</b>	Empty-loaded lever does not lock.	<ul style="list-style-type: none"> <li>• Move the pulley back and forth using the control valve. The locking pin will be engaged.</li> </ul>
	Damaged return spring on the empty-loaded lever	<ul style="list-style-type: none"> <li>• Contact the manufacturer</li> </ul>
	Damaged gear system	<ul style="list-style-type: none"> <li>• Contact the manufacturer</li> </ul>
<b>The empty-loaded lever of the hoisting rope is not locked.</b>	Damaged or jammed empty-loaded lever shaft	<ul style="list-style-type: none"> <li>• Contact the manufacturer</li> </ul>
	Damaged return spring on the empty-loaded lever	<ul style="list-style-type: none"> <li>• Contact the manufacturer</li> </ul>
	Pin not snapping into the socket	<ul style="list-style-type: none"> <li>• Move the pulley back and forth using the control valve. The locking pin will be engaged.</li> </ul>
<b>The Hydraulic winch is shaking out during the pulling process.</b>	Damaged hydromotor	<ul style="list-style-type: none"> <li>• Contact the manufacturer</li> </ul>
	Contaminated hydraulic oil and filters	<ul style="list-style-type: none"> <li>• Clean or change the hydraulic oil and the filters</li> </ul>
	Air inside the hydraulic system	<ul style="list-style-type: none"> <li>• Deaerate the system</li> </ul>
	Contaminated control valve	<ul style="list-style-type: none"> <li>• Clean up the contaminated valve.</li> </ul>
	Damaged hydraulic brake	<ul style="list-style-type: none"> <li>• Contact the manufacturer</li> </ul>
	Low oil flow	<ul style="list-style-type: none"> <li>• Increase the oil flow of the system.</li> </ul>

The rope in the Hydraulic winch should not be used when damaged due to abrasion and corrosion. Otherwise, it may lead to serious accidents. The drawing, against which certain actions are required to be taken, can be seen as follows in this respect.

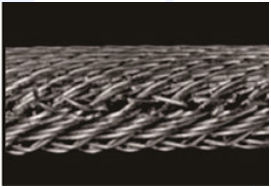
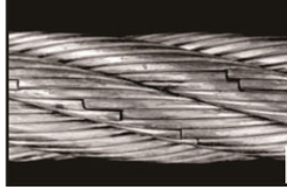
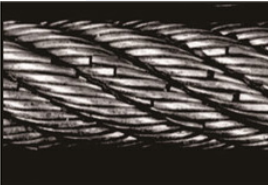
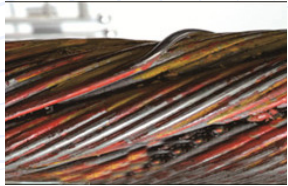
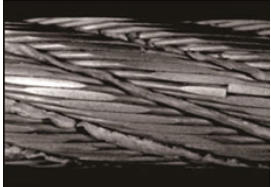
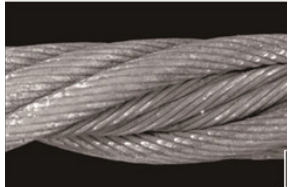
**Under such circumstances, the rope must be replaced with a new one.**

<p><b>1</b> Movement of the rope on the sharp edge under load</p> 	<p><b>6</b> Corrosion</p> 
<p><b>2</b> Abrasion on the supporting structure.</p> 	<p><b>7</b> Wire breakage due to twisting wear-out</p> 
<p><b>3</b> Wearing out and rupture of the rope due to working on a wide/narrow groove and pulley</p> 	<p><b>8</b> Wire breakage on the middle surface, which is named as castle breakage</p> 
<p><b>4</b> Abrasion due to the pressure applied on the wires</p> 	<p><b>9</b> Detachment of the vein due to applying of high pressure</p> 
<p><b>5</b> Abrasion due to wearing out and friction</p> 	<p><b>10</b> "Bird Cage" occurring on untwisted ropes due to unbalanced twisting</p> 

- ▶ Where the Crane is brought in pieces, it will not be covered under the warranty.
- ▶ No part that has experienced an accident is covered under the warranty.
- ▶ Failure of a product due to taking or replacing a part of the change is not covered under the warranty.
- ▶ The cranes that are recognized to have been misused are not covered under the warranty.
- ▶ The Crane can only be used for rescue purposes. Those that are used for any other purposes are not covered under the warranty.
- ▶ This warranty covers the manufacturing defects, workmanship and material faults, along with the mechanical parts.
- ▶ The steel rope and the hook is not covered under the warranty.
- ▶ The scope of the warranty does not cover the standard wear-out and abrasion, Crane accidents, misuse, crash, overloading, modification, malpractices, faulty assembly situations.
- ▶ It is a must for the customer to detach the Crane and deliver it to the plant with the shipping company as determined by "TORAco".
- ▶ All the shipping costs shall be covered by the crane owner.
- ▶ The owner of the product shall be responsible for any and all the shipping costs until it is accepted that the problem in the product is covered under the warranty. In the event that the problem will be solved once the part that is deemed required to be changed is sent to the owner, the spare part shall be sent to the "product owner" at his/her own cost. Under such circumstances, "TORAco" may request the broken parts to be sent. "TORAco" reserves the right to make changes on the Warranty Terms.

**TORA LLC**



📍 11417 IL 19, Franklin Park, IL 60131  
☎️ (630) 785-2410  
📞 (331) 688-4947  
🌐 [www.toracompany.com](http://www.toracompany.com)  
✉️ [info@toracompany.com](mailto:info@toracompany.com)



[toracompany](https://www.facebook.com/toracompany)



[tora.company](https://www.instagram.com/tora.company)



[www.toracompany.com](http://www.toracompany.com)