

# TCF-20 Hydraulic Cooling Fan

Max Flow (GPM)	Capacity (kcal/h)
31.5	12000

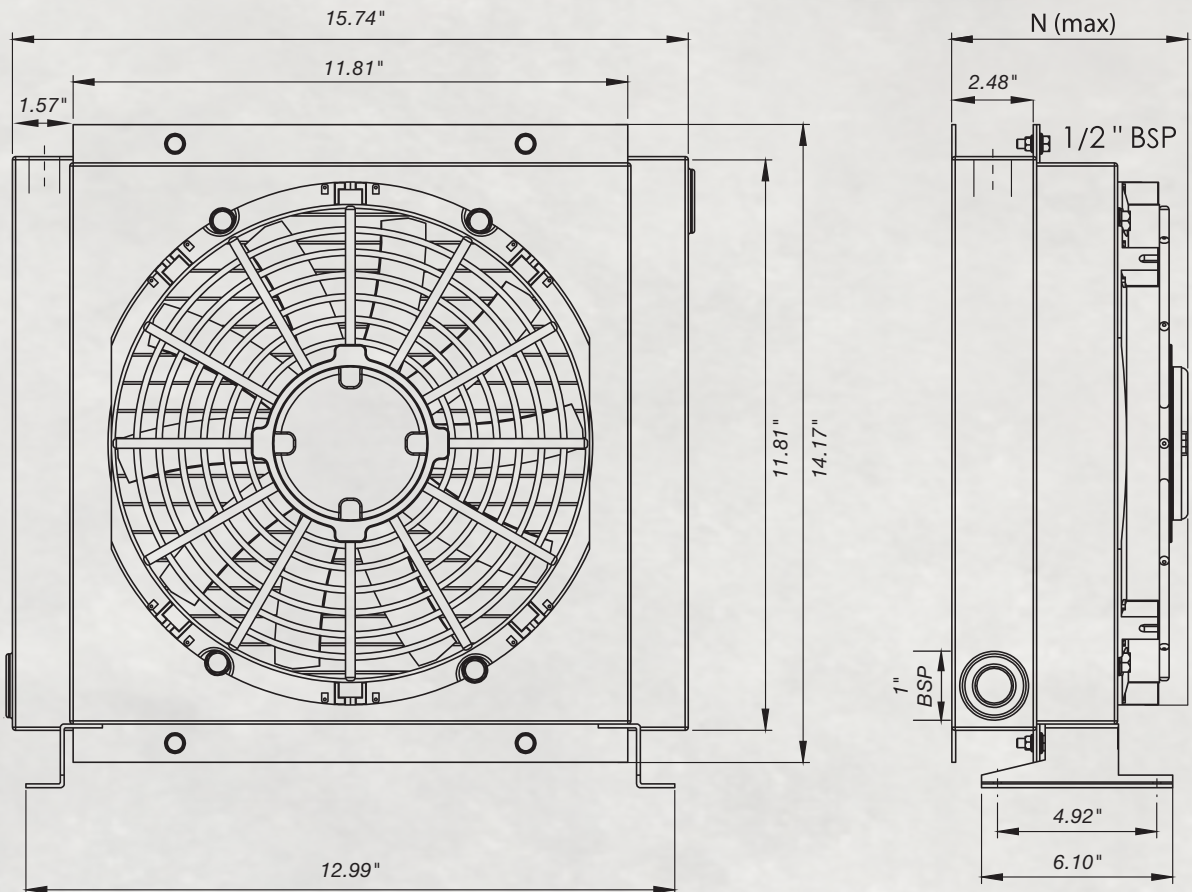

Voltage	Fan Diameter	Fan Speed (RPM)	dB(A) 1M	Power (HP)	Operation Pressure (PSI)	N (Max)
12 & 24	9.64"	2700	74	0.14	362	7.36"
230 & 400	9.84"	2800	72	0.13	362	9.33"