



HYDRAULIC WINCH TECHNICAL CATALOG



YOUR
IS OUR **SUCCESS**



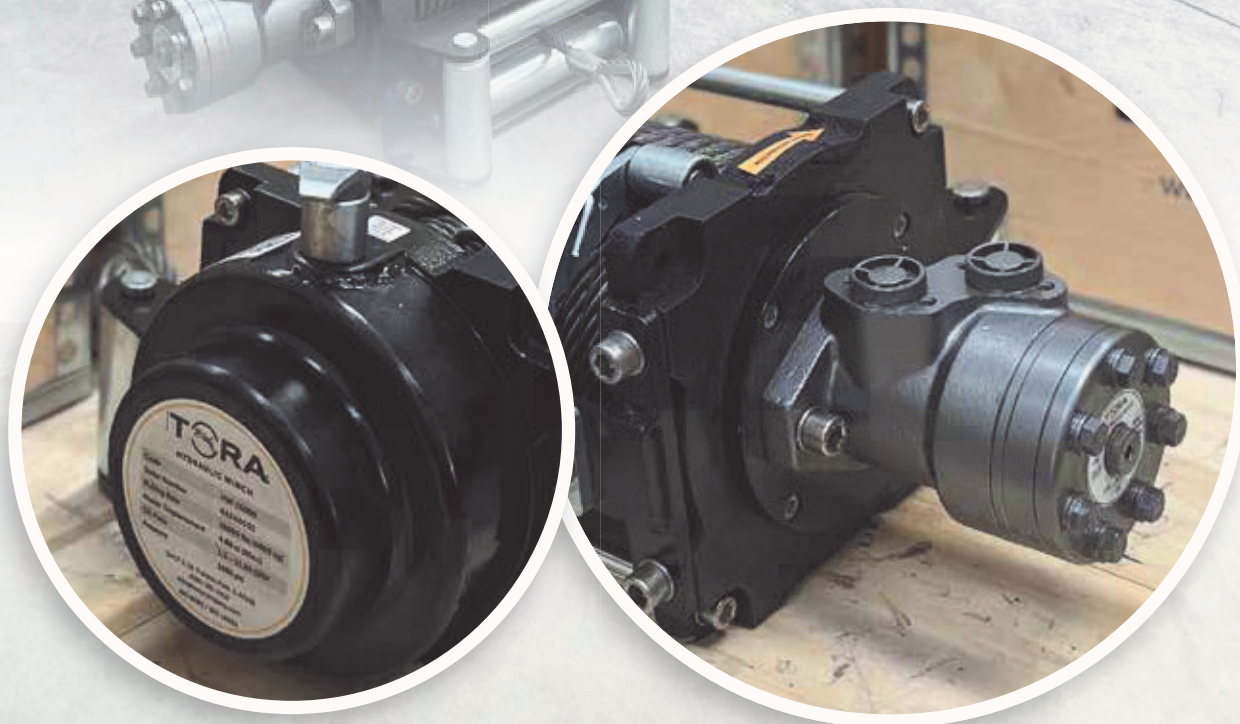

HW SERIES HYDRAULIC WINCHES FEATURES

- » High-strength, long-lasting steel body
- » Extra reinforced planetary gear system with special steel heat treatment
- » Lightweight and powerful design
- » Standard winch guide system and rope stabiliser
- » Manual winch discharge system provided as standard
- » High torque hydromotor



HW-10000

- High-strength, long-lasting steel body
- Extra reinforced planetary gear system with special steel heat treatment
- Lightweight and powerful design
- Standard winch guide system and rope stabiliser
- Manual winch discharge system provided as standard
- High torque hydromotor

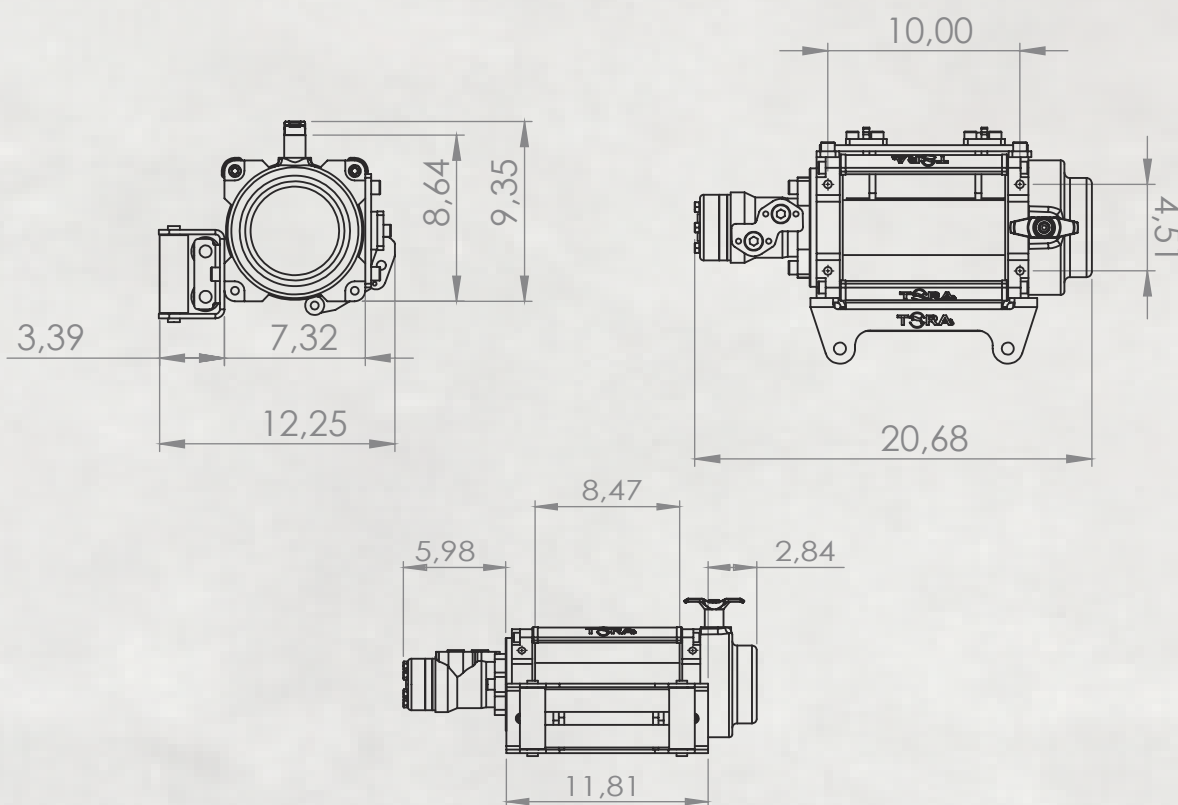
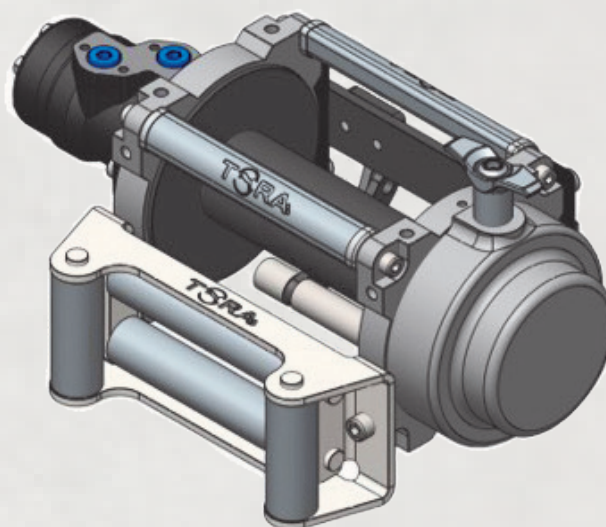

Maximum Pulling Force	10000 lbs
Maximum Rope Diameter	25/64"
Maximum Pump Flow	1.3 ~ 11.88 gpm
Maximum Operating Pressure	1668 psi
Weight	143 lbs

Rope Winding Count	Pulling Capacity lbs
1	10000
2	8012
3	6683
4	5732

HW-12000

- High-strength, long-lasting steel body
- Extra reinforced planetary gear system with special steel heat treatment
- Lightweight and powerful design
- Standard winch guide system and rope stabiliser
- Manual winch discharge system provided as standard
- High torque hydromotor

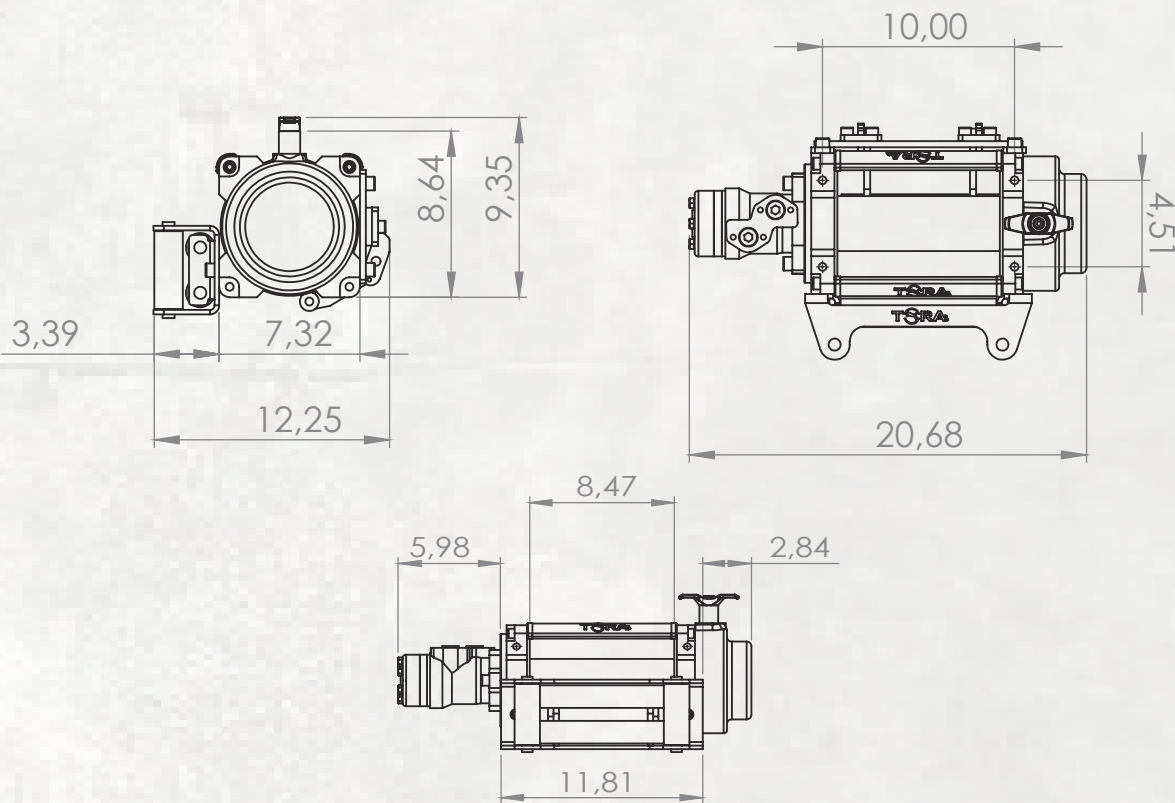
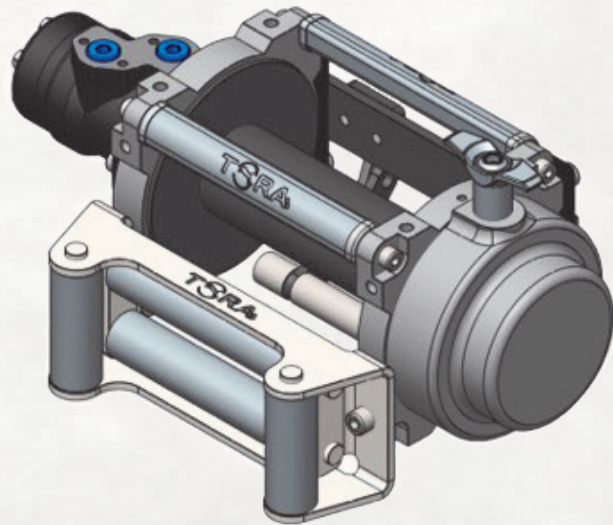

Maximum Pulling Force	12000 lbs
Maximum Rope Diameter	15/32"
Maximum Pump Flow	1.3 ~ 11.88 gpm
Maximum Operating Pressure	2030 psi
Weight	143 lbs

Rope Winding Count	Pulling Capacity lbs
1	12000
2	10595
3	9485
4	7904

HW-15000

- High-strength, long-lasting steel body
- Extra reinforced planetary gear system with special steel heat treatment
- Lightweight and powerful design
- Standard winch guide system and rope stabiliser
- Manual winch discharge system provided as standard
- High torque hydromotor

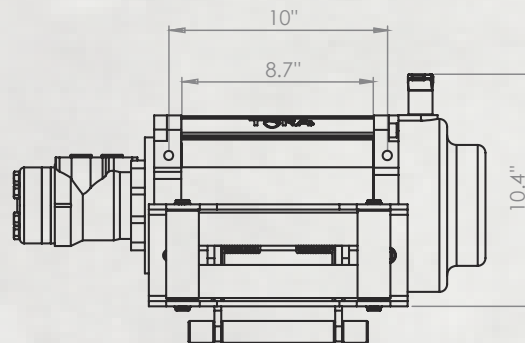
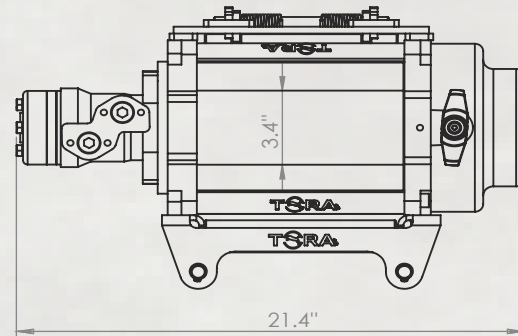
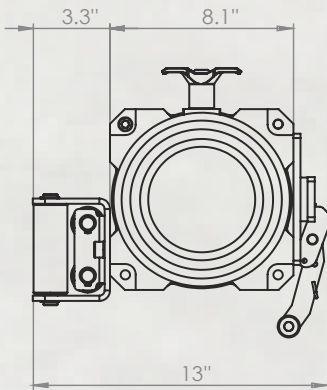
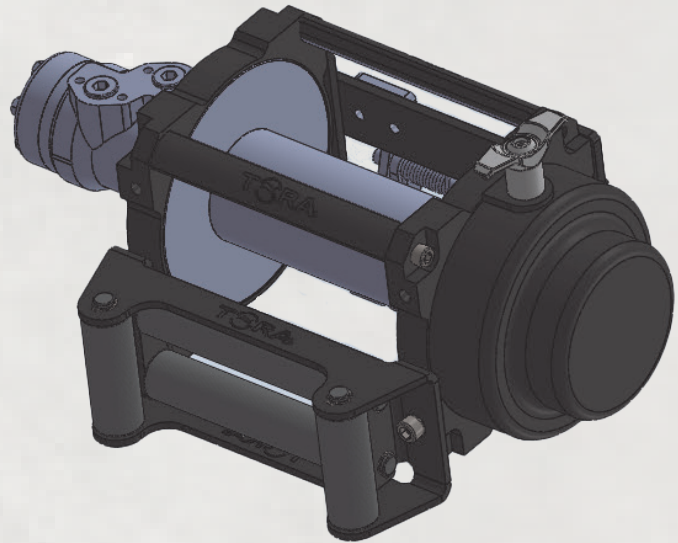

Maximum Pulling Force	15000 lbs
Maximum Rope Diameter	15/32"
Maximum Pump Flow	1.3 ~ 15.85 gpm
Maximum Operating Pressure	1885 psi
Weight	152lbs

Rope Winding Count	Pulling Capacity lbs
1	15000
2	12120
3	10168
4	8757



THW SERIES HYDRAULIC WINCHES FEATURES

- » High-strength, long-lasting steel body
- » Extra reinforced planetary gear system with special steel heat treatment
- » Lightweight and powerful design
- » 100% negative effective hydraulic disc brake system
- » Standard winch guide system and rope stabiliser
- » Manual winch discharge system provided as standard
- » High torque hydromotor



THW-8K

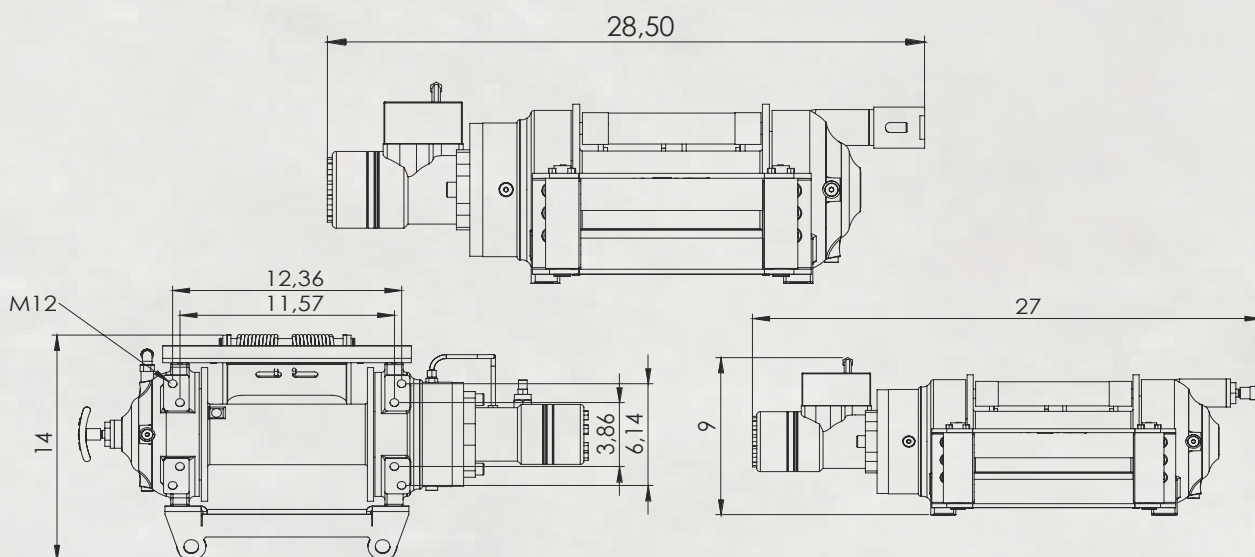
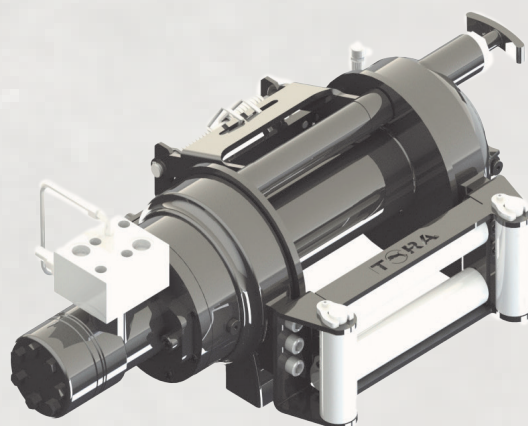
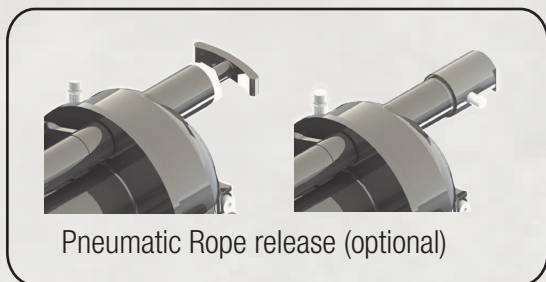

Rope Winding Count	Pulling Capacity lbs	Winding Speed ft-min	Rope Length ft
1	8000	58	22
2	6700	64	47
3	5776	71	74
4	5070	77	103
5	4523	83	134

Maximum Pulling Force	8000 lbs
Maximum Rope Diameter	3/8"
Maximum Pump Flow	15.8 gpm
Maximum Operating Pressure	1740 psi
Recommended Gear Oil Product	80w 90 - 23.6 fl oz
Weight	138 lbs
Maximum Rope Length	134 ft
Hydromotor	12 in ³
Gear Ratio	5/1

THW-10K

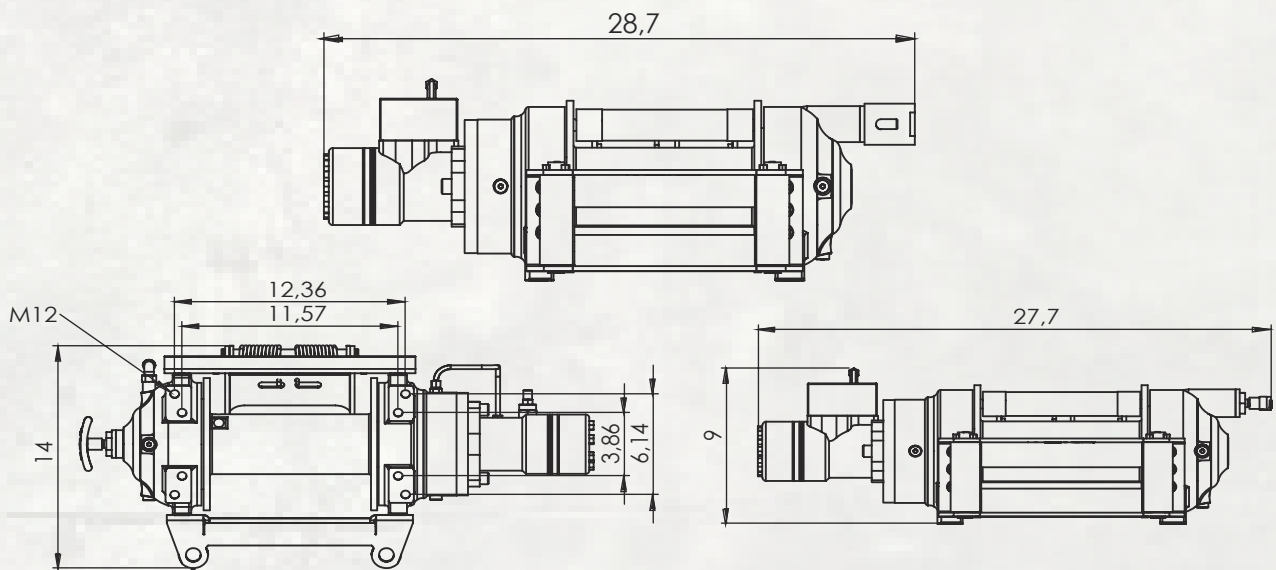
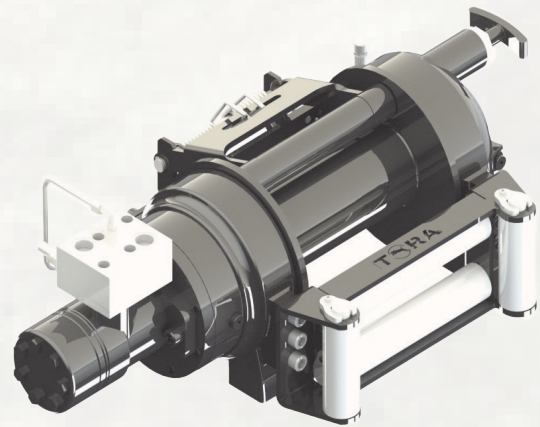
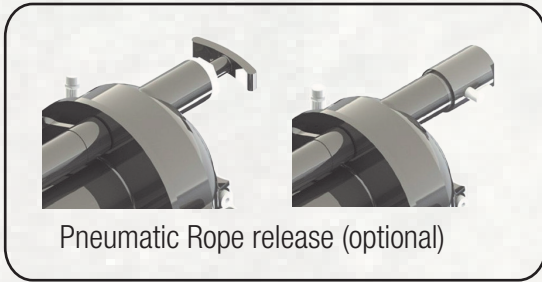

Rope Winding Count	Pulling Capacity lbs	Winding Speed ft-min	Rope Length ft
1	10000	47	22
2	8370	52	47
3	7215	57	74
4	6342	62	103
5	5657	66	134

Maximum Pulling Force	10000 lbs
Maximum Rope Diameter	3/8"
Maximum Pump Flow	15.8 gpm
Maximum Operating Pressure	2030 psi
Recommended Gear Oil Product	80w 90 - 23.6 fl oz
Weight	141 lbs
Maximum Rope Length	134 ft
Hydromotor	15 in ³
Gear Ratio	5/1w



THW-12K

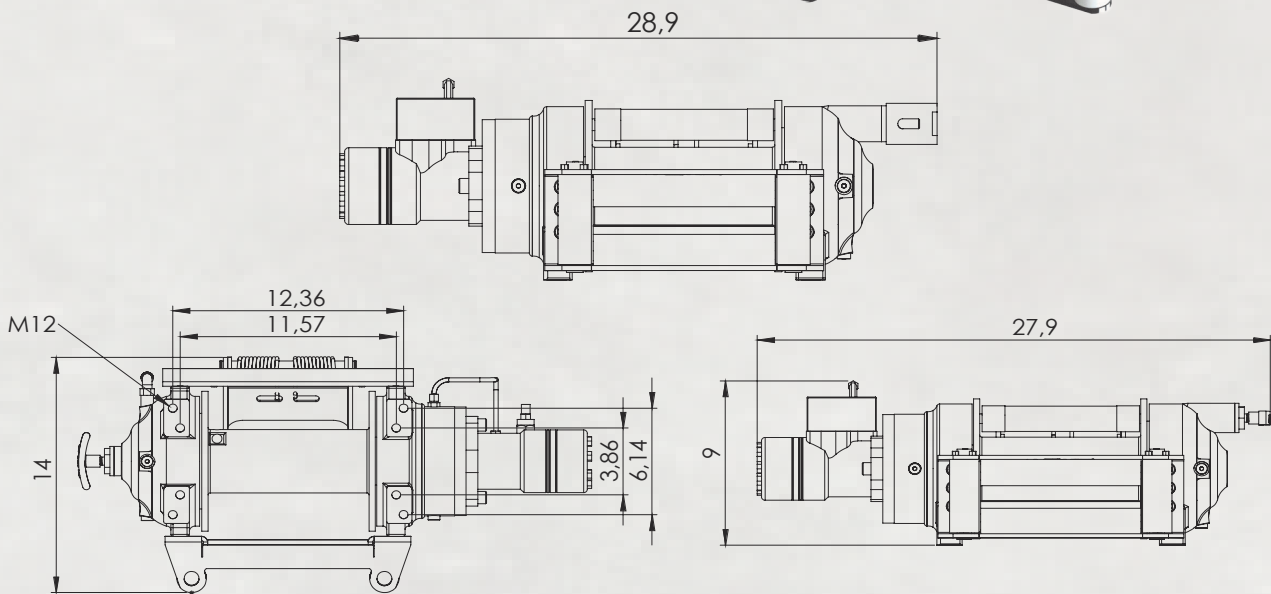
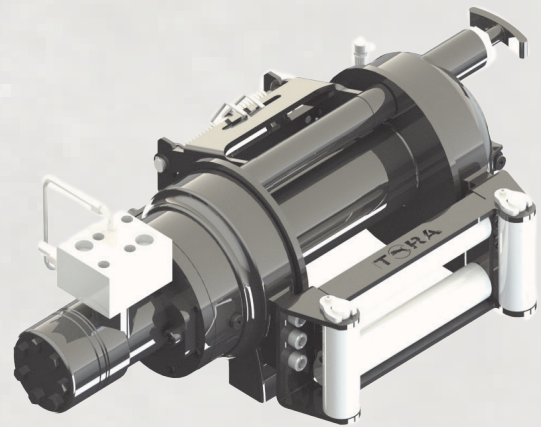
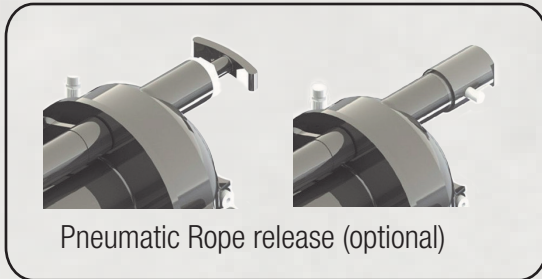

Rope Winding Count	Pulling Capacity lbs	Winding Speed ft-min	Rope Length ft
1	12000	37	19
2	9920	41	40
3	8510	46	63
4	7360	50	88
5	6494	55	116

Maximum Pulling Force	12000 lbs
Maximum Rope Diameter	1/2"
Maximum Pump Flow	15.8 gpm
Maximum Operating Pressure	1885 psi
Recommended Gear Oil Product	80w 90 - 23.6 fl oz
Weight	143 lbs
Maximum Rope Length	116 ft
Hydromotor	19.2 in ³
Gear Ratio	5/1

THW-15K

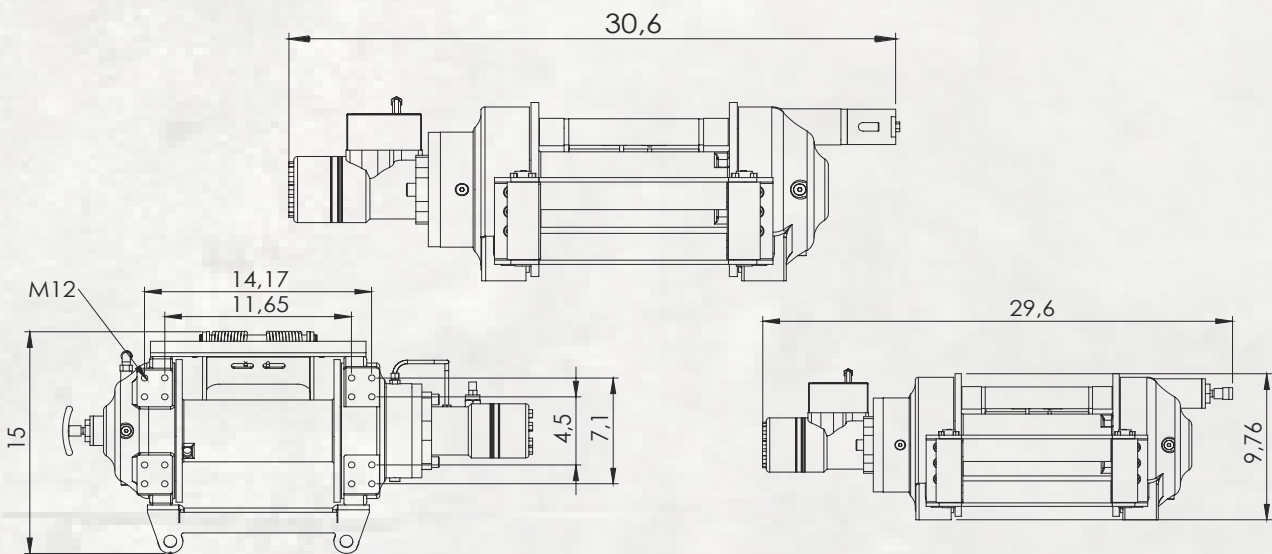
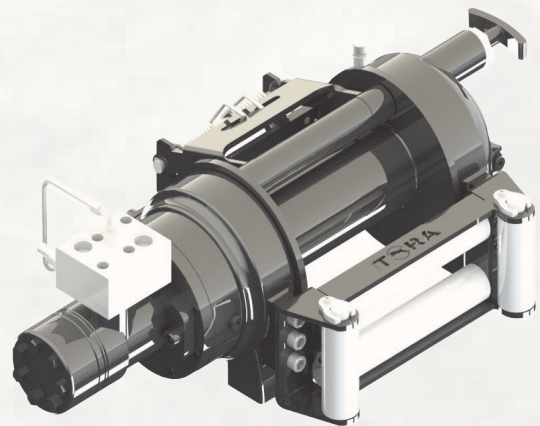
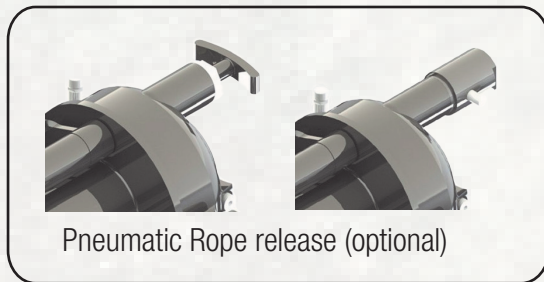

Rope Winding Count	Pulling Capacity lbs	Winding Speed ft-min	Rope Length ft
1	15000	34	22
2	12425	38	48
3	10617	41	75
4	9268	45	106
5	8223	49	139
6	7392	53	173

Maximum Pulling Force	15000 lbs
Maximum Rope Diameter	1/2"
Maximum Pump Flow	15.8 gpm
Maximum Operating Pressure	2248 psi
Recommended Gear Oil Product	80w 90 - 27 fl oz
Weight	180 lbs
Maximum Rope Length	173 ft
Hydromotor	19.2 in ³
Gear Ratio	6/1

THW-16K

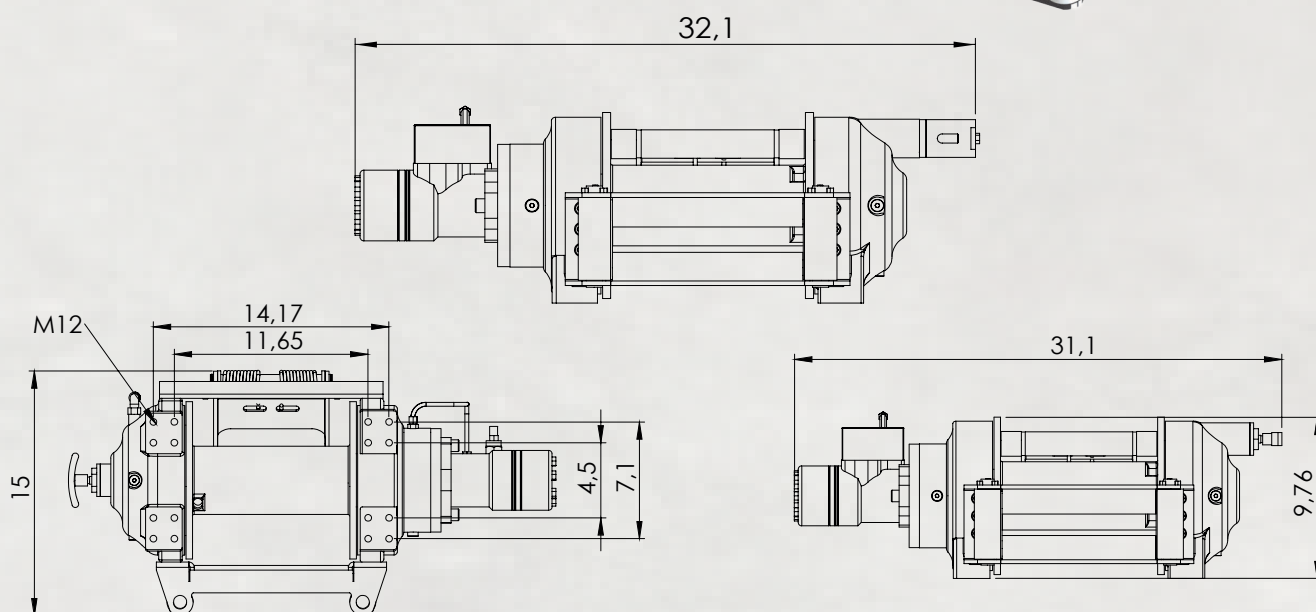
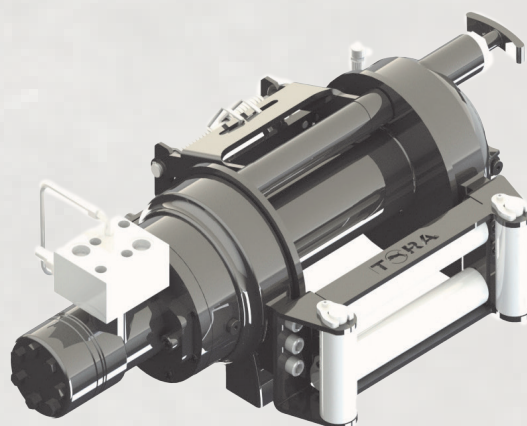
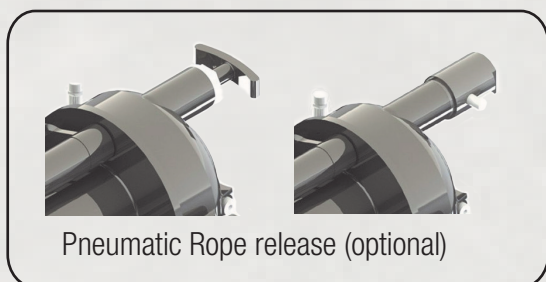

Rope Winding Count	Pulling Capacity lbs	Winding Speed ft-min	Rope Length ft
1	15000	34	19
2	12425	38	41
3	10617	43	66
4	9268	47	94
5	8223	52	131

Maximum Pulling Force	16000 lbs
Maximum Rope Diameter	3/9"
Maximum Pump Flow	15.8 gpm
Maximum Operating Pressure	2393 psi
Recommended Gear Oil Product	80w 90 - 27 fl oz
Weight	185 lbs
Maximum Rope Length	131 ft
Hydromotor	19 in ³
Gear Ratio	6/1

THW-18K

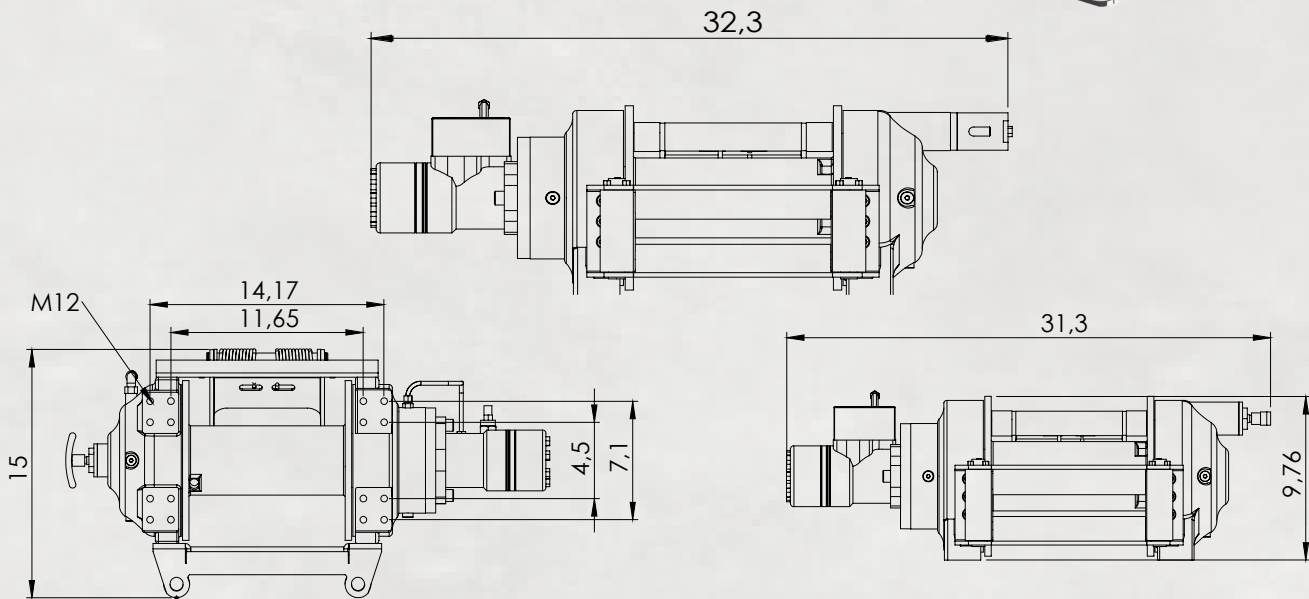
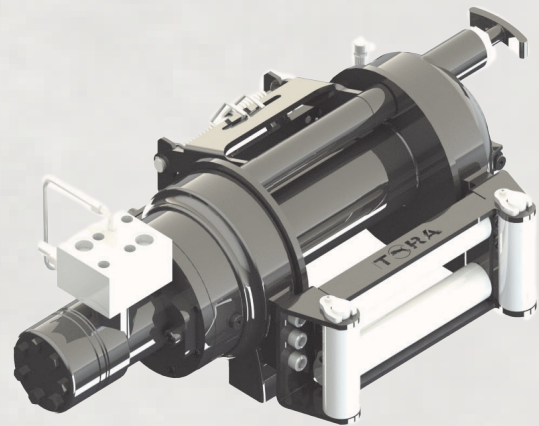
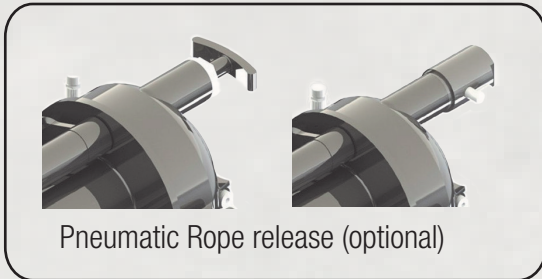

Rope Winding Count	Pulling Capacity lbs	Winding Speed ft-min	Rope Length ft
1	18000	27	19
2	14645	31	41
3	12301	35	66
4	10604	38	94
5	9318	41	131

Maximum Pulling Force	18000 lbs
Maximum Rope Diameter	3/9"
Maximum Pump Flow	15.8 gpm
Maximum Operating Pressure	2175 psi
Recommended Gear Oil Product	80w 90 - 27 fl oz
Weight	187 lbs
Maximum Rope Length	131 ft
Hydromotor	24 in ³
Gear Ratio	6/1



THW-22K

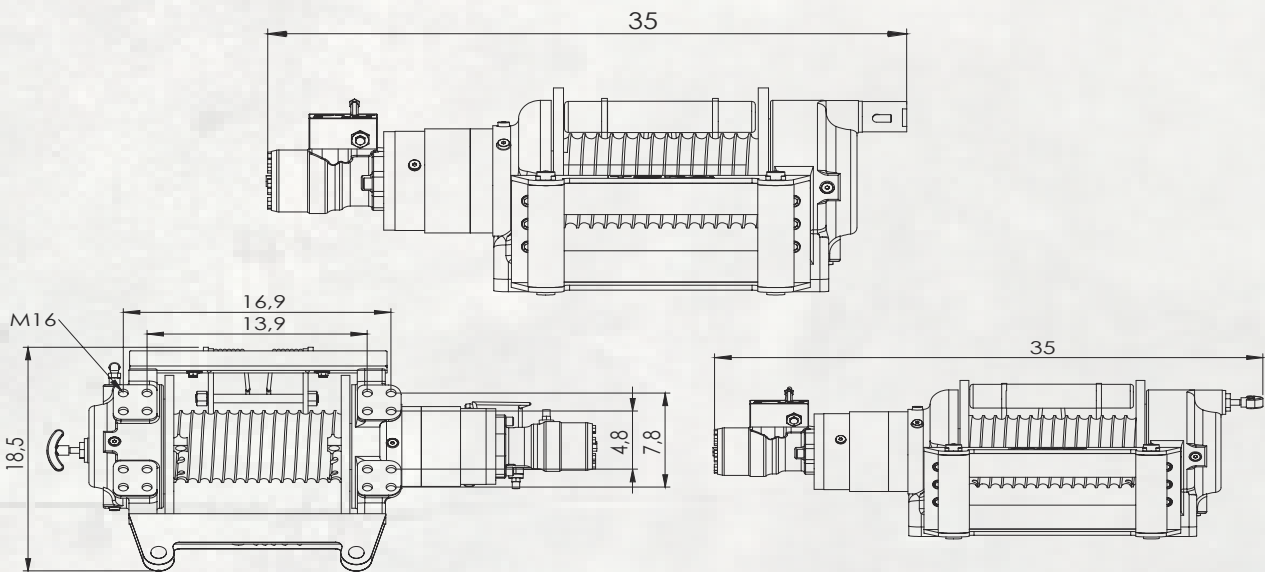
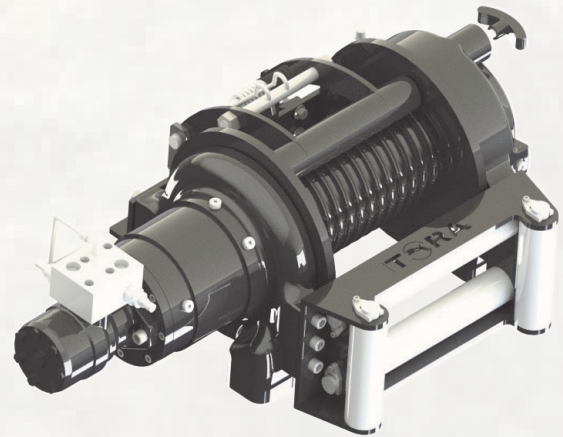
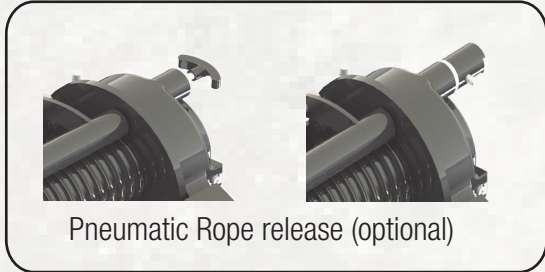

Rope Winding Count	Pulling Capacity lbs	Winding Speed ft-min	Rope Length ft
1	22000	25	19
2	18346	28	43
3	15628	31	72
4	13611	34	105
5	12054	37	141

Maximum Pulling Force	22000 lbs
Maximum Rope Diameter	7/11"
Maximum Pump Flow	15.8 gpm
Maximum Operating Pressure	2346 psi
Recommended Gear Oil Product	80w 90 - 33.8 fl oz
Weight	330 lbs
Maximum Rope Length	141 ft
Hydromotor	10 in ³
Gear Ratio	21/1

THW-26K

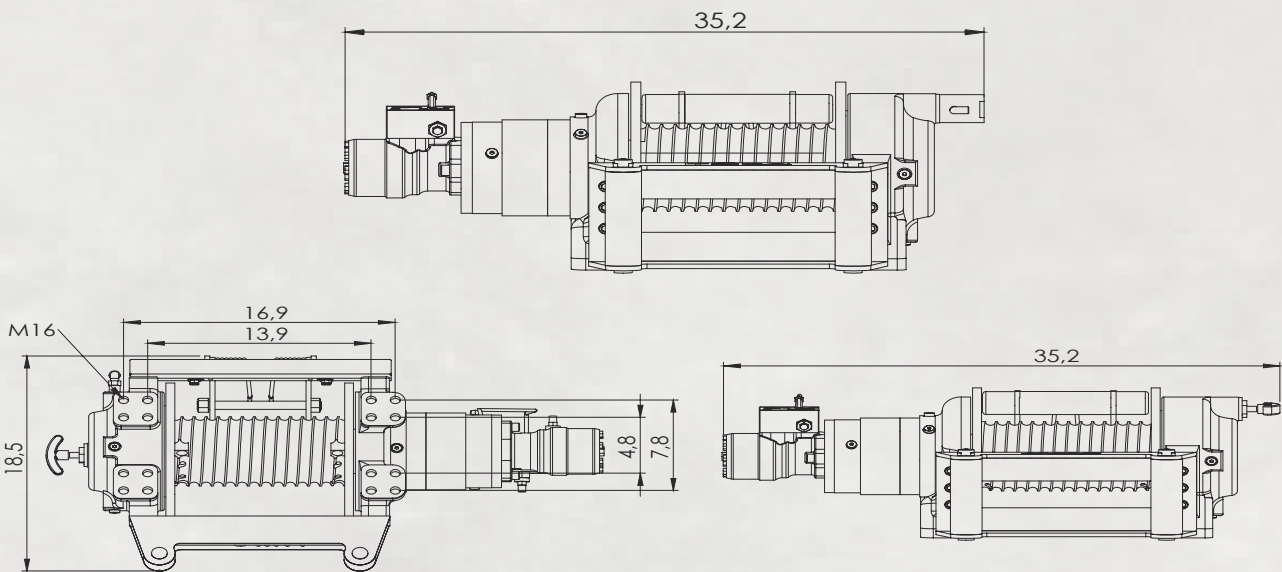
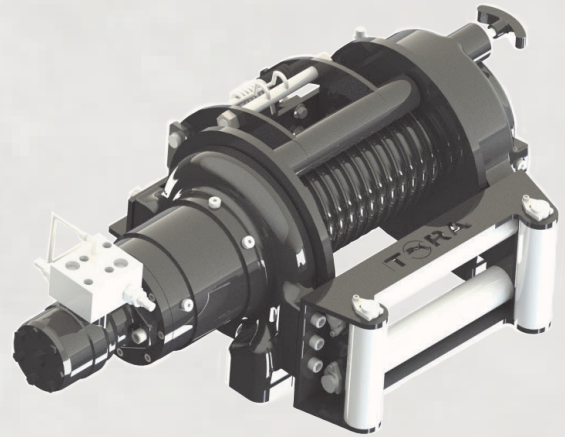
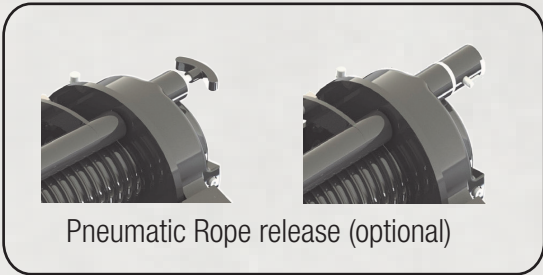

Rope Winding Count	Pulling Capacity lbs	Winding Speed ft-min	Rope Length ft
1	26500	20	19
2	21841	22	43
3	18607	25	72
4	16203	27	105
5	14352	30	141

Maximum Pulling Force	26500 lbs
Maximum Rope Diameter	5/8"
Maximum Pump Flow	15.8 gpm
Maximum Operating Pressure	2320 psi
Recommended Gear Oil Product	80w 90 - 34 fl oz
Weight	341 lbs
Maximum Rope Length	141 ft
Hydromotor	12 in ³
Gear Ratio	21/1



THW-33K

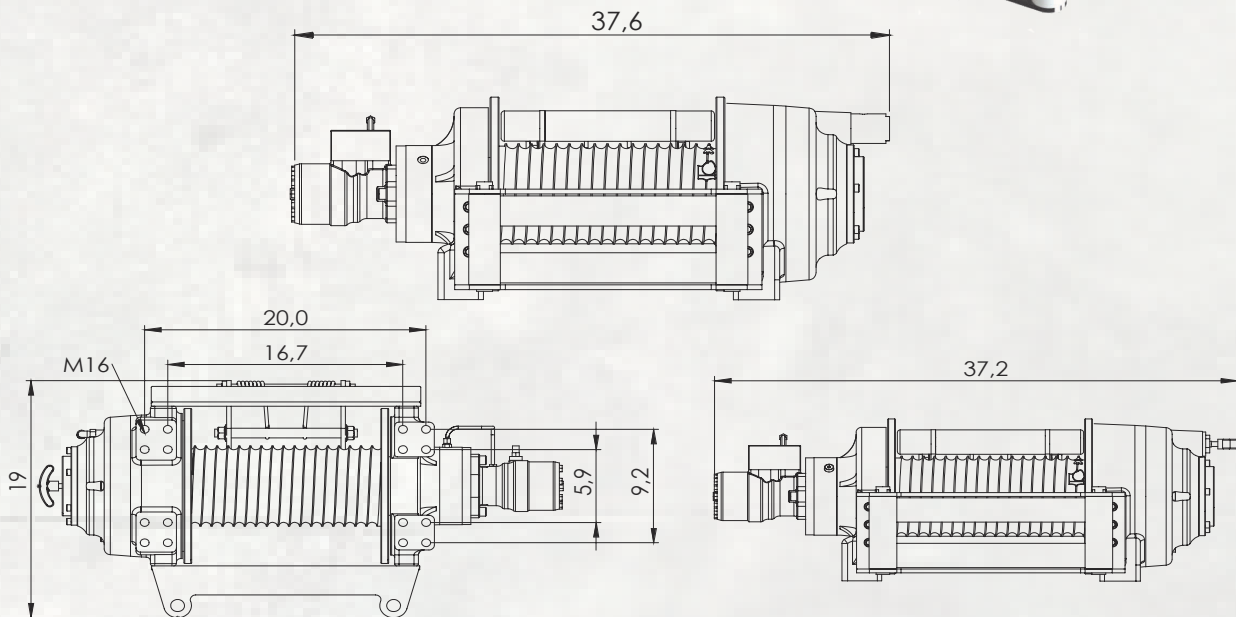
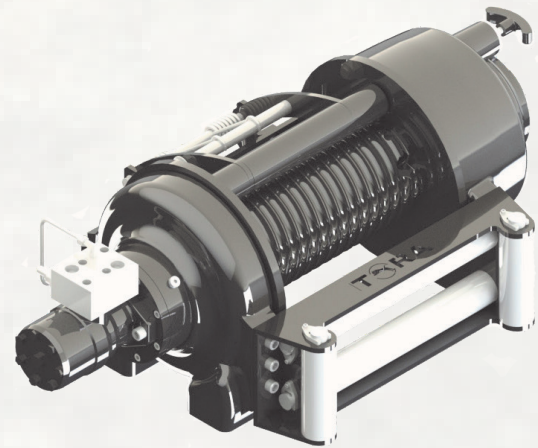
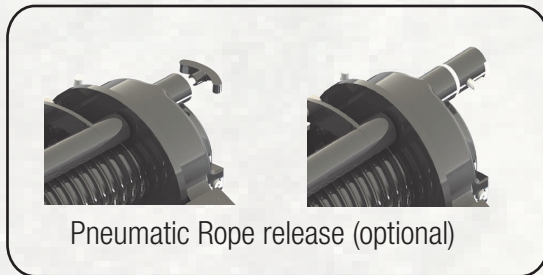

Rope Winding Count	Pulling Capacity lbs	Winding Speed ft-min	Rope Length ft
1	33000	16	24
2	27844	18	55
3	23682	20	91
4	20593	22	137

Maximum Pulling Force	33000 lbs
Maximum Rope Diameter	45/64"
Maximum Pump Flow	15.8 gpm
Maximum Operating Pressure	2393 psi
Recommended Gear Oil Product	80w 90 - 68 fl oz
Weight	429 lbs
Maximum Rope Length	137 ft
Hydromotor	10 in ³
Gear Ratio	36/1

THW-40K

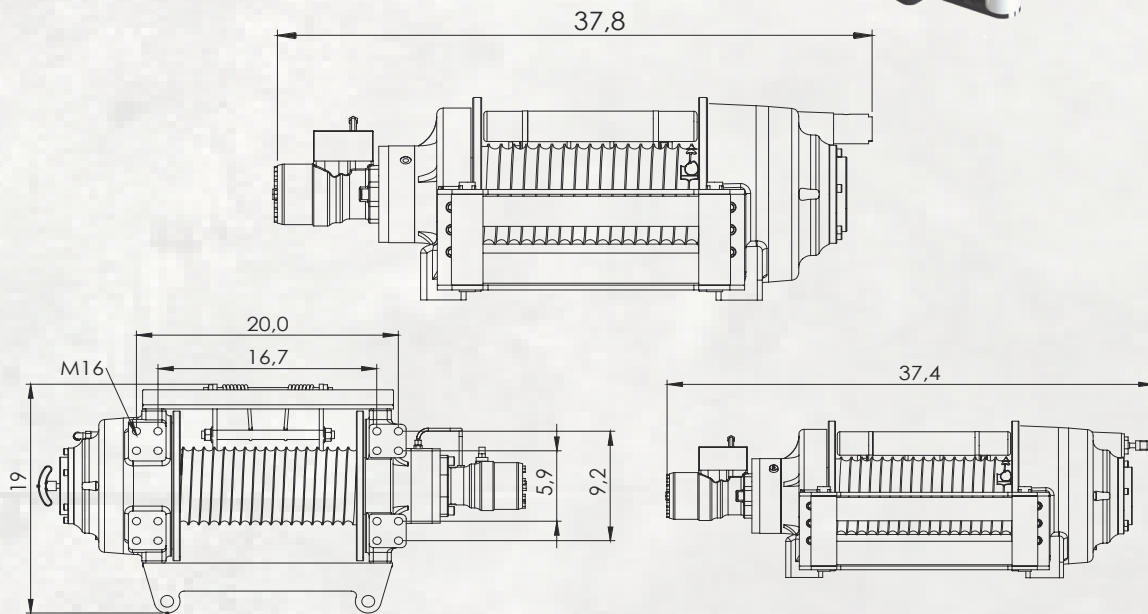
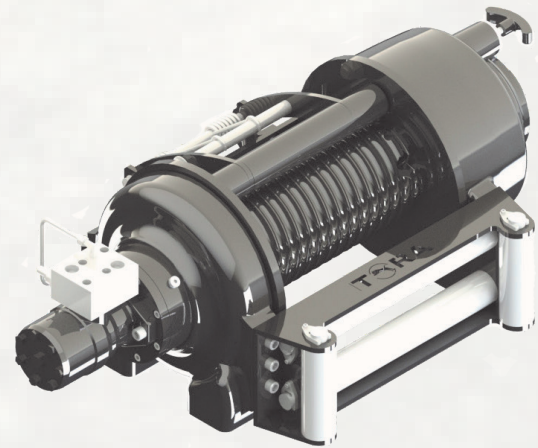
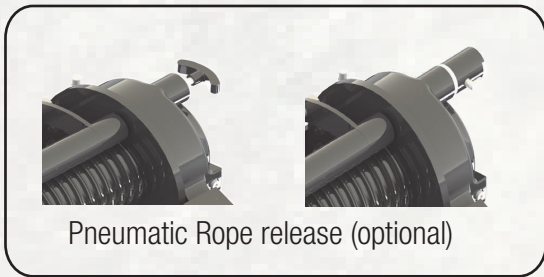

Rope Winding Count	Pulling Capacity lbs	Winding Speed ft-min	Rope Length ft
1	40000	14	24
2	32716	15	55
3	27809	17	91
4	14180	19	137

Maximum Pulling Force	40000 lbs
Maximum Rope Diameter	45/64"
Maximum Pump Flow	15.8 gpm
Maximum Operating Pressure	2393 psi
Recommended Gear Oil Product	80w 90 - 68 fl oz
Weight	441 lbs
Maximum Rope Length	137 ft
Hydromotor	12 in ³
Gear Ratio	36/1

THW-66K

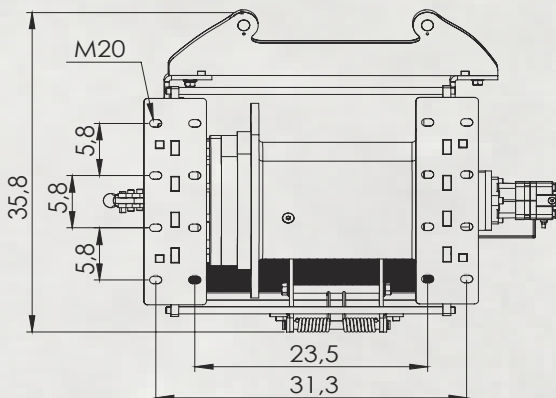
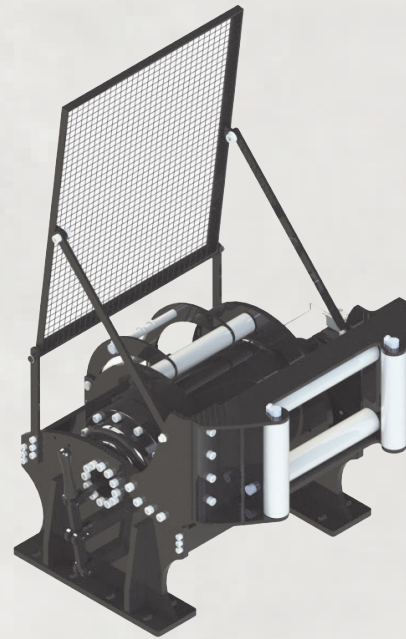
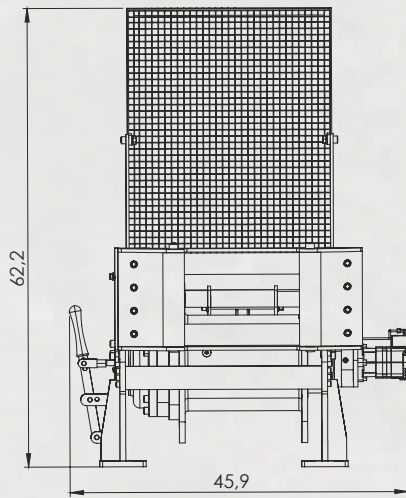

Maximum Pulling Force	66000 lbs
Maximum Rope Diameter	45/64"
Maximum Pump Flow	19.8 gpm
Maximum Operating Pressure	2393 psi
Recommended Gear Oil Product	80w 90 - 135 fl oz
Weight	1069 lbs
Maximum Rope Length	242 ft
Hydromotor	9.6 in ³
Gear Ratio	150/1

Rope Winding Count	Pulling Capacity lbs	Winding Speed ft-min	Rope Length ft
1	66000	11	54
2	58047	12	113
3	51482	14	175
4	45252	16	242

THW-77K

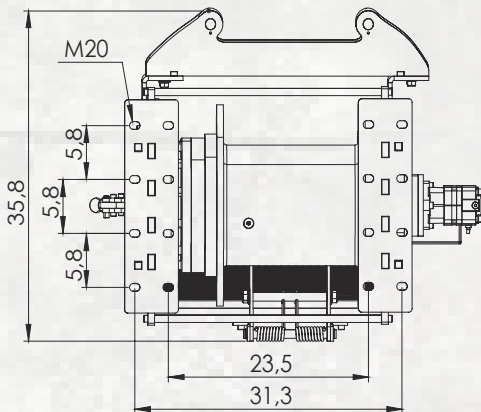
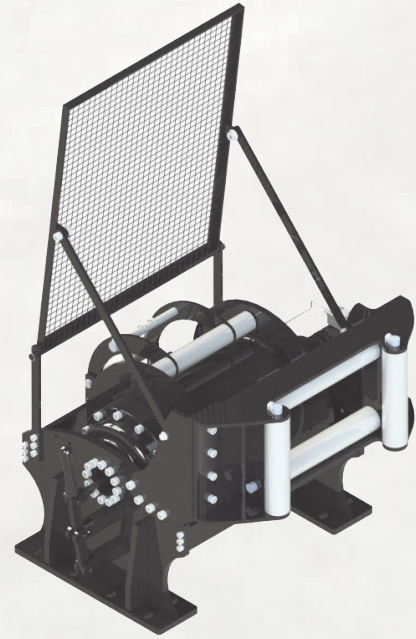
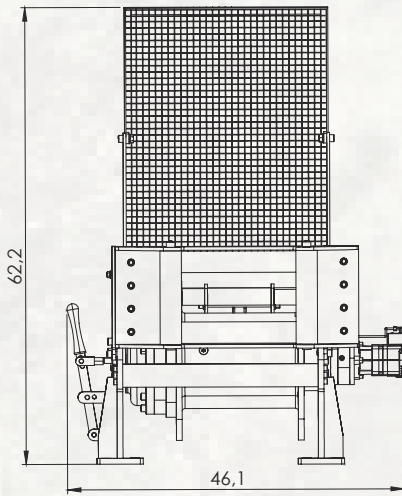

Maximum Pulling Force	77000 lbs
Maximum Rope Diameter	45/64"
Maximum Pump Flow	19.8 gpm
Maximum Operating Pressure	2248 psi
Recommended Gear Oil Product	80w 90 - 135 fl oz
Weight	1080 lbs
Maximum Rope Length	229 ft
Hydromotor	12 in ³
Gear Ratio	150/1

Rope Winding Count	Pulling Capacity lbs	Winding Speed ft-min	Rope Length ft
1	77000	8	50
2	67170	9	105
3	59167	10	166
4	52869	11	229



HYDRAULIC WINCH TECHNICAL CATALOG



 www.toracompany.com
 www.kmspowertakeoff.com
 info@toracompany.com
 11417 IL 19, Franklin Park, IL 60131
 (630) 785-2410
 (331) 688-4947



[toracompany](https://www.facebook.com/toracompany)



[tora.company](https://www.instagram.com/tora_company)



www.toracompany.com



YOUR
IS OUR **SUCCESS**

