



HYDRAULIC COOLING FAN



Code	Max Flow (GPM)	Capacity (kcal/h)
TCF-01	10.5	2000
TCF-05	21	5500
TCF-10	26	6000
TCF-20	31.5	12000
TCF-30	37	20000
TCF-40	42	25000
TCF-50	47.5	40000
TCF-60	58	60000



TCF-01 Hydraulic Cooling Fan

Max Flow (GPM)	Capacity (kcal/h)
10.5	2000

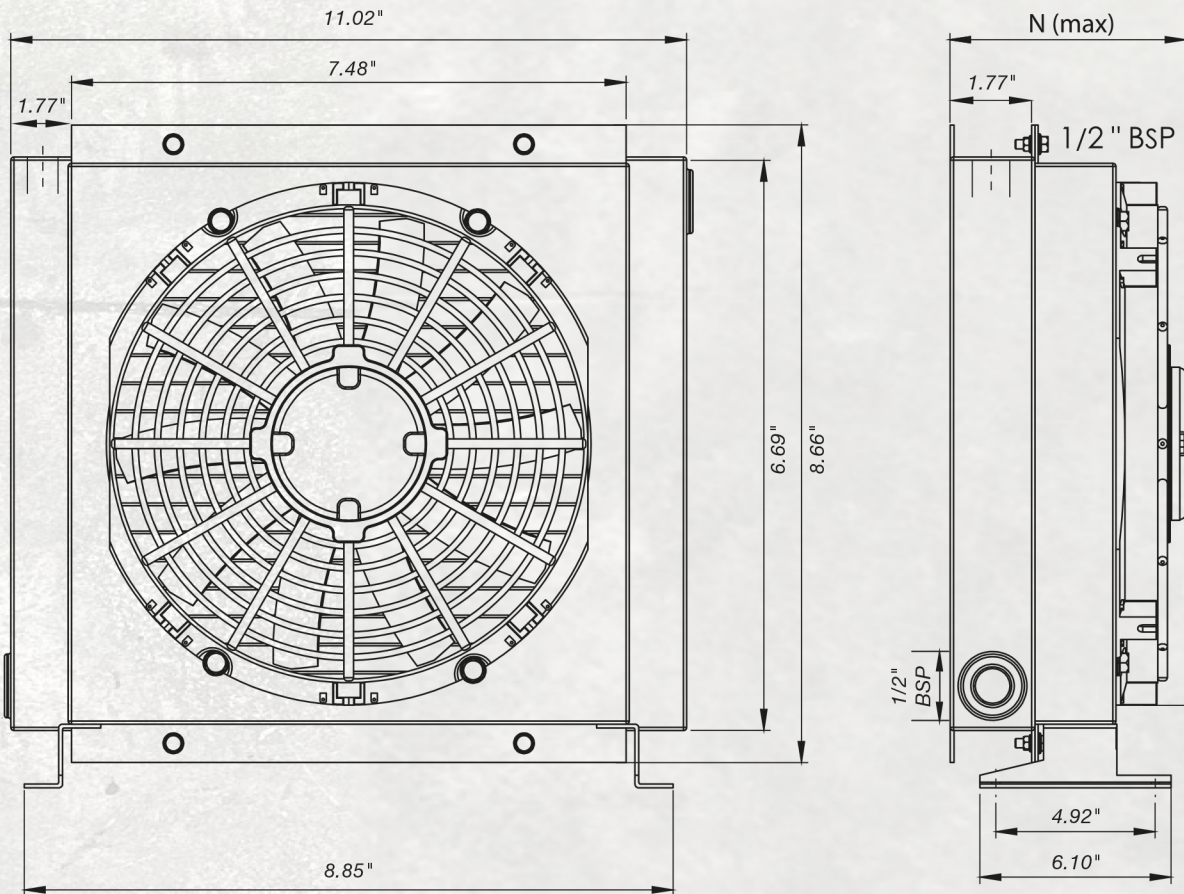

Voltage	Fan Diameter	Fan Speed (RPM)	dB(A) 1M	Power (HP)	Operation Pressure (PSI)	N (Max)
12 & 24	6.10"	750	51	0.05	362	6.77"
230 & 400	6.30"	700	50	0.06	362	8.54"

TCF-05 Hydraulic Cooling Fan



Max Flow (GPM)	Capacity (kcal/h)
21	5500

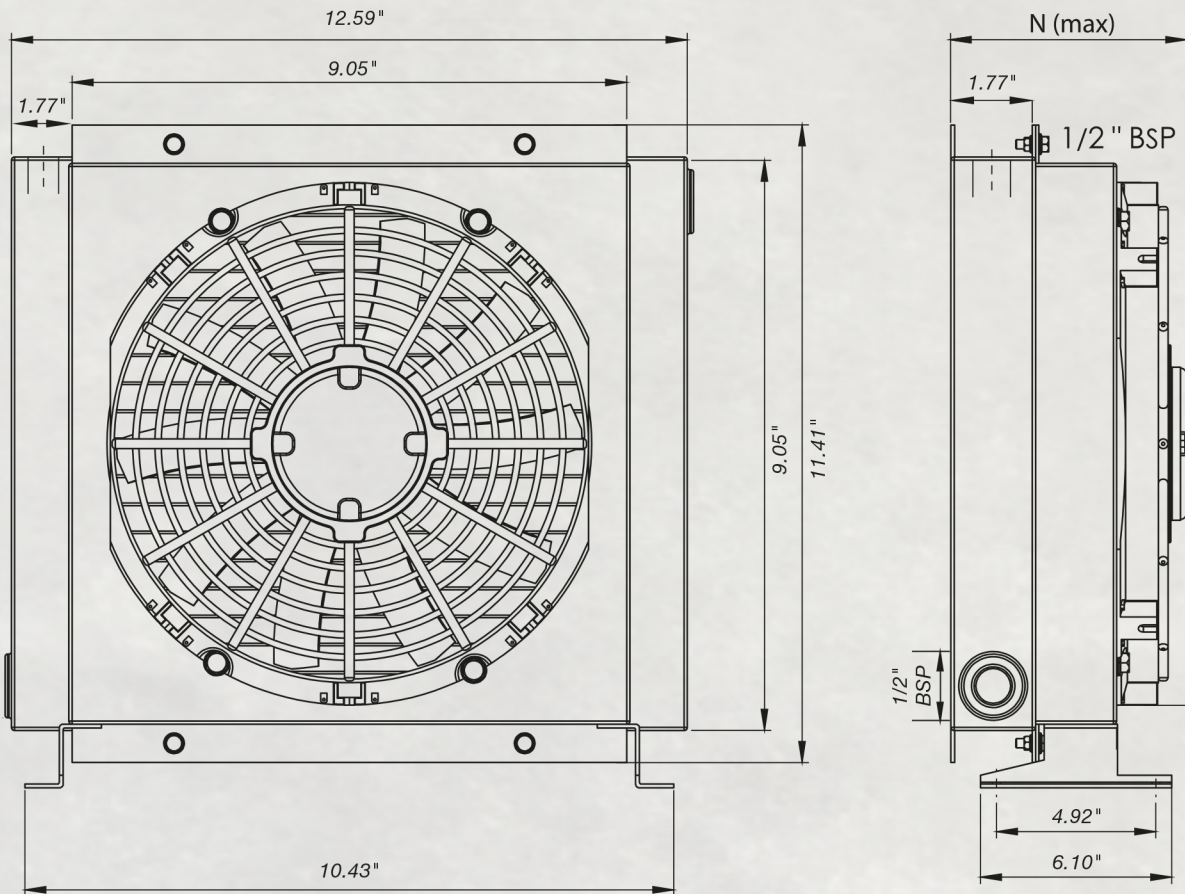

Voltage	Fan Diameter	Fan Speed (RPM)	dB(A) 1M	Power (HP)	Operation Pressure (PSI)	N (Max)
12	7.67"	2700	72	0.12	362	6.77"
24	7.67"	2700	72	0.13	362	6.77"
230 & 400	7.87"	2800	68	0.08	362	8.54"

TCF-10 Hydraulic Cooling Fan

Max Flow (GPM)	Capacity (kcal/h)
26	6000

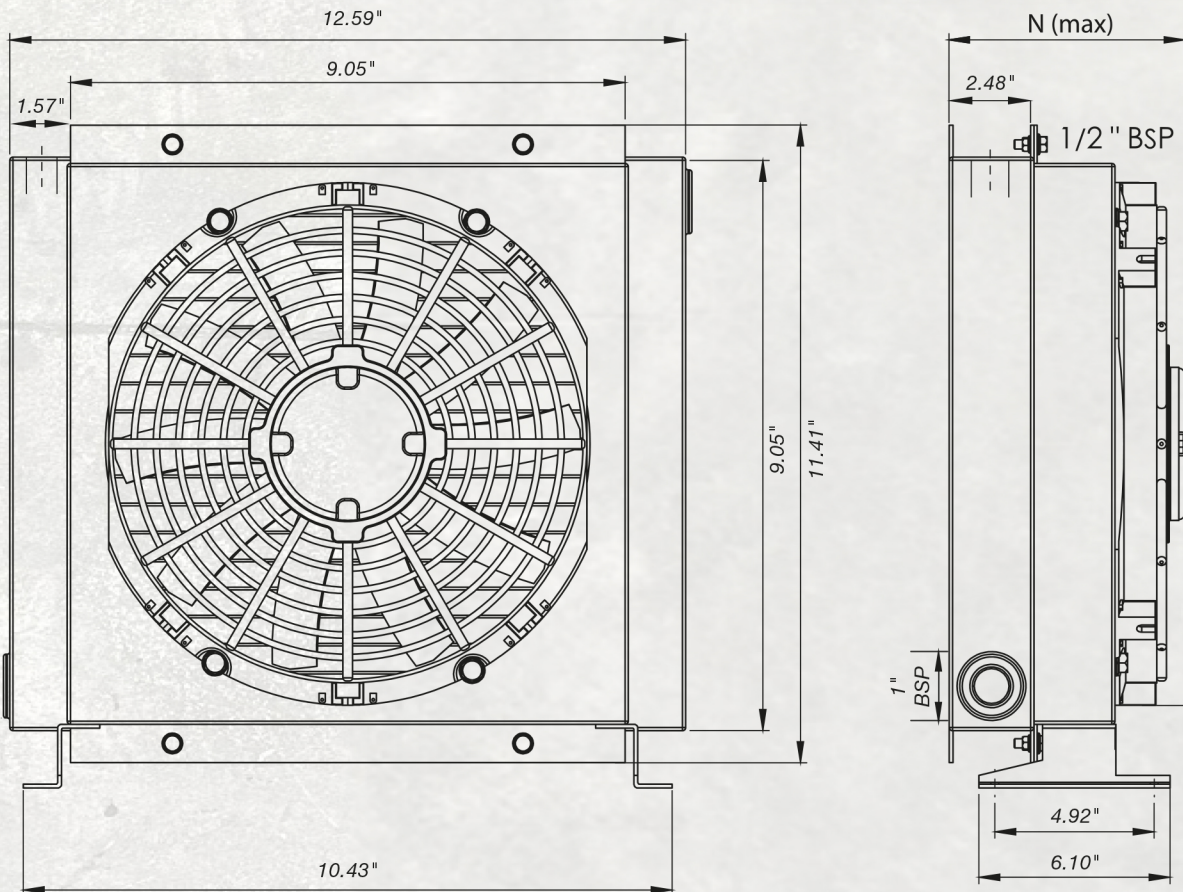

Voltage	Fan Diameter	Fan Speed (RPM)	dB(A) 1M	Power (HP)	Operation Pressure (PSI)	N (Max)
12	7.67"	2700	72	0.12	362	7.36"
24	7.67"	2700	72	0.13	362	7.36"
230 & 400	7.87"	2800	68	0.08	362	9.13"

TCF-20 Hydraulic Cooling Fan

Max Flow (GPM)	Capacity (kcal/h)
31.5	12000

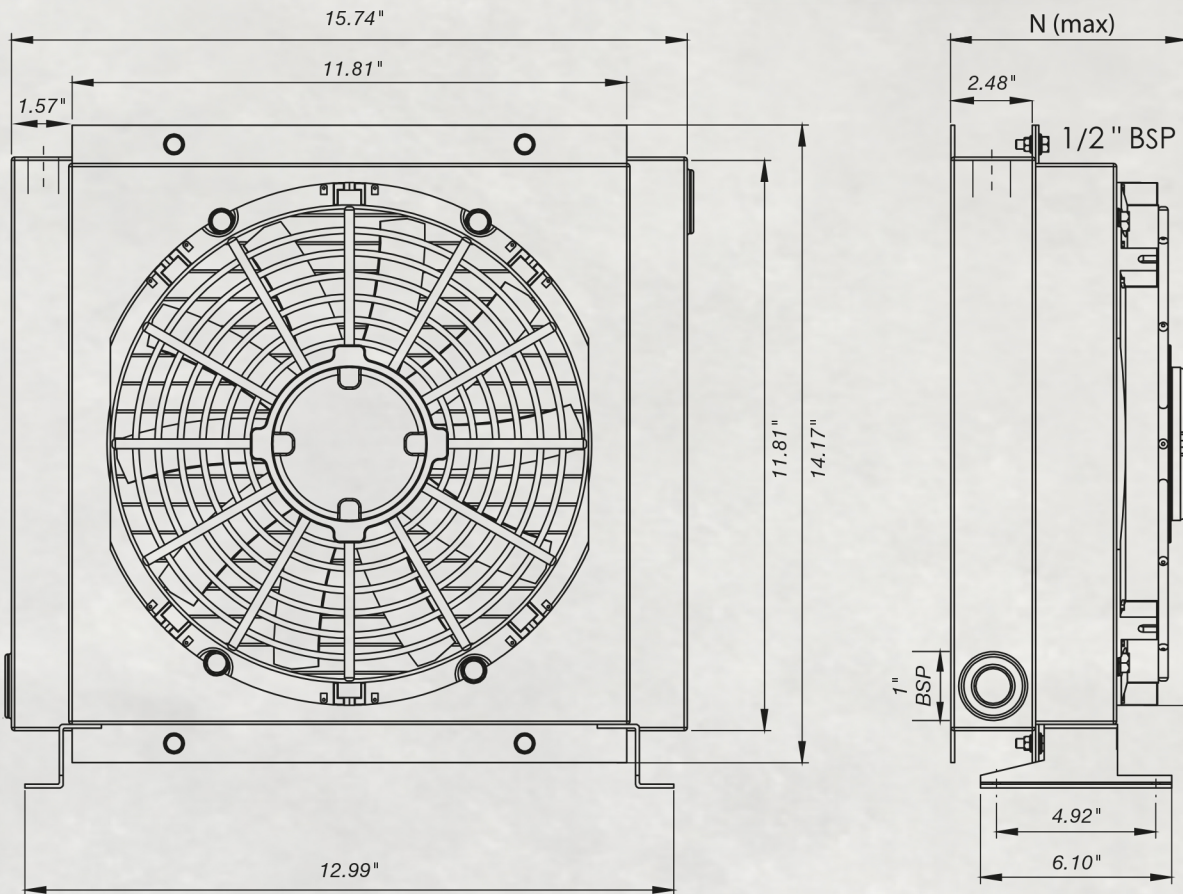

Voltage	Fan Diameter	Fan Speed (RPM)	dB(A) 1M	Power (HP)	Operation Pressure (PSI)	N (Max)
12 & 24	9.64"	2700	74	0.14	362	7.36"
230 & 400	9.84"	2800	72	0.13	362	9.33"

TCF-30 Hydraulic Cooling Fan

Max Flow (GPM)	Capacity (kcal/h)
37	20000

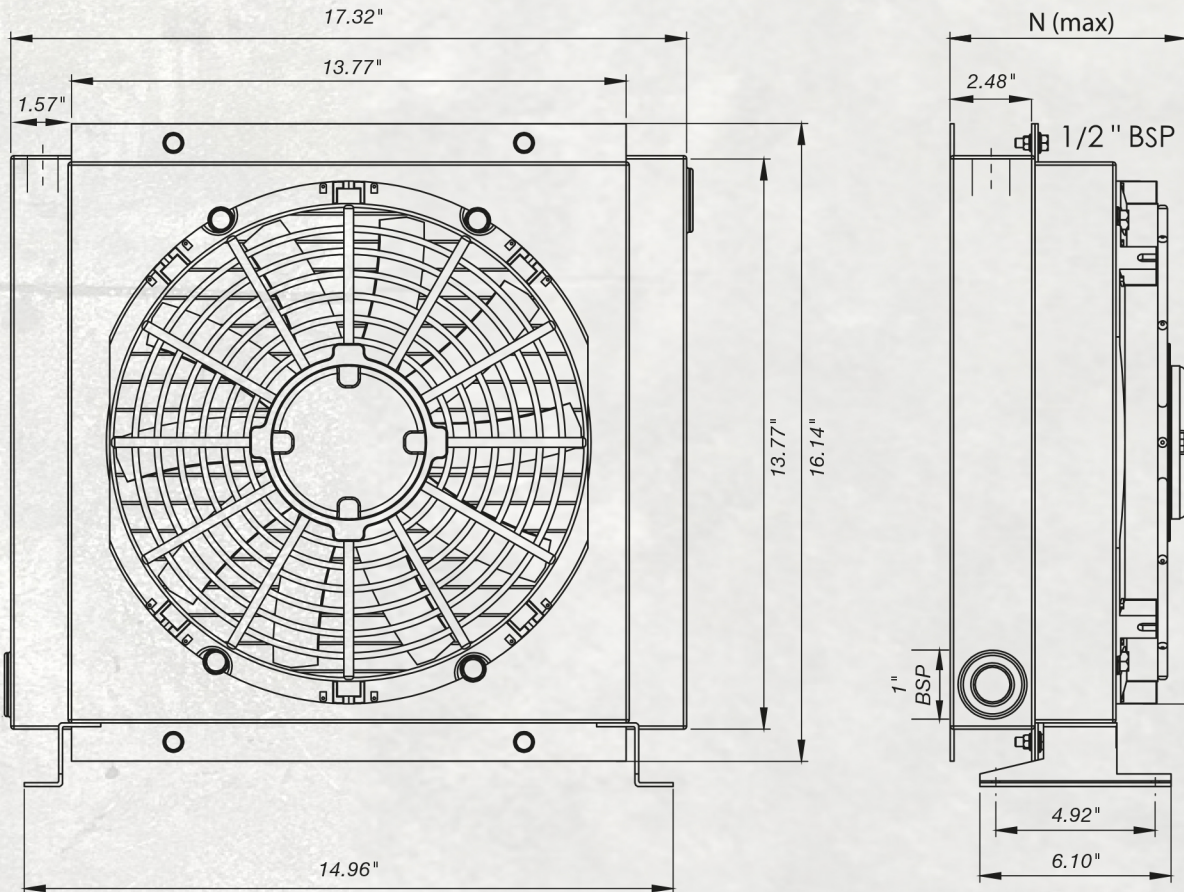

Voltage	Fan Diameter	Fan Speed (RPM)	dB(A) 1M	Power (HP)	Operation Pressure (PSI)	N (Max)
12 & 24	11.41"	2700	74	0.24	362	7.36"
230 & 400	11.81"	2800	72	0.25	362	9.52"

TCF-40 Hydraulic Cooling Fan



Max Flow (GPM)	Capacity (kcal/h)
42	25000

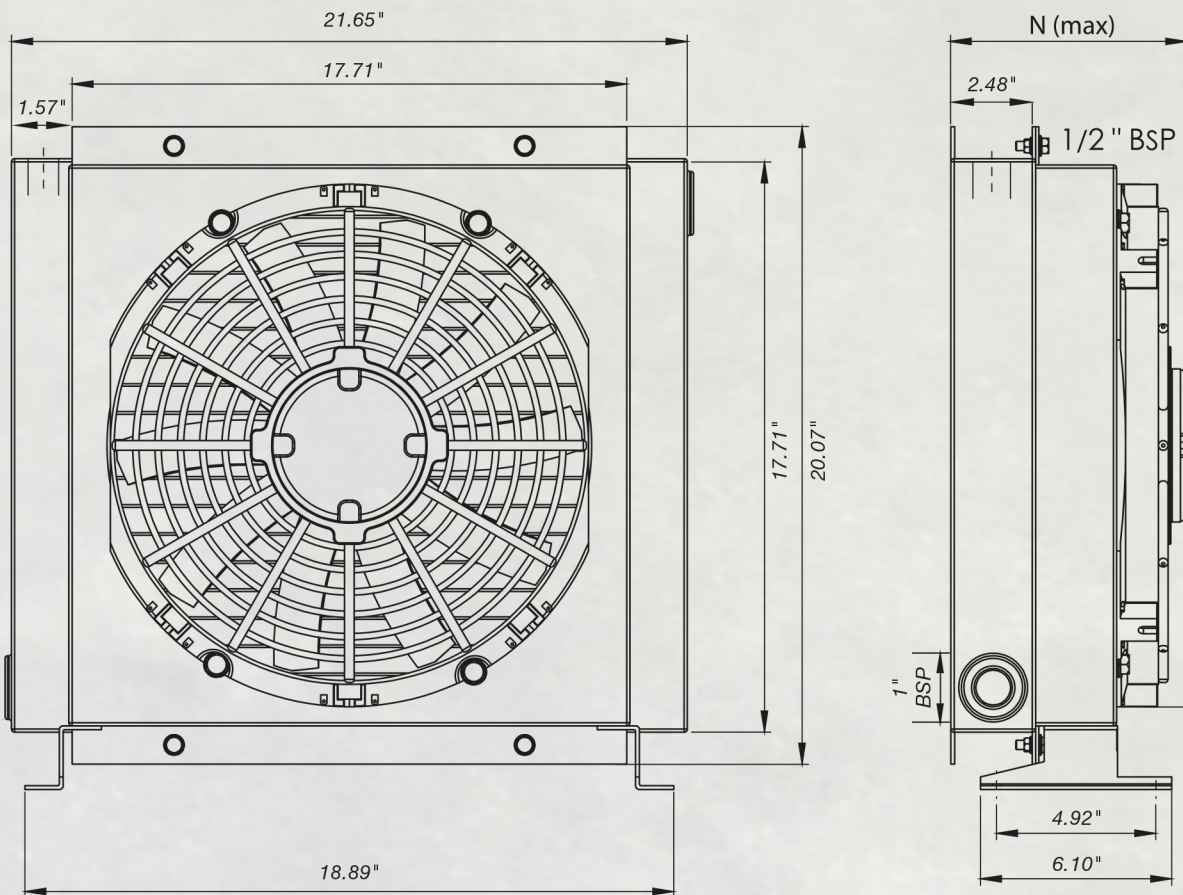

Voltage	Fan Diameter	Fan Speed (RPM)	dB(A) 1M	Power (HP)	Operation Pressure (PSI)	N (Max)
12 & 24	13.58"	2700	78	0.28	362	7.36"
230 & 400	13.77"	2800	74	0.43	362	10.11"

TCF-50 Hydraulic Cooling Fan

Max Flow (GPM)	Capacity (kcal/h)
47.5	40000

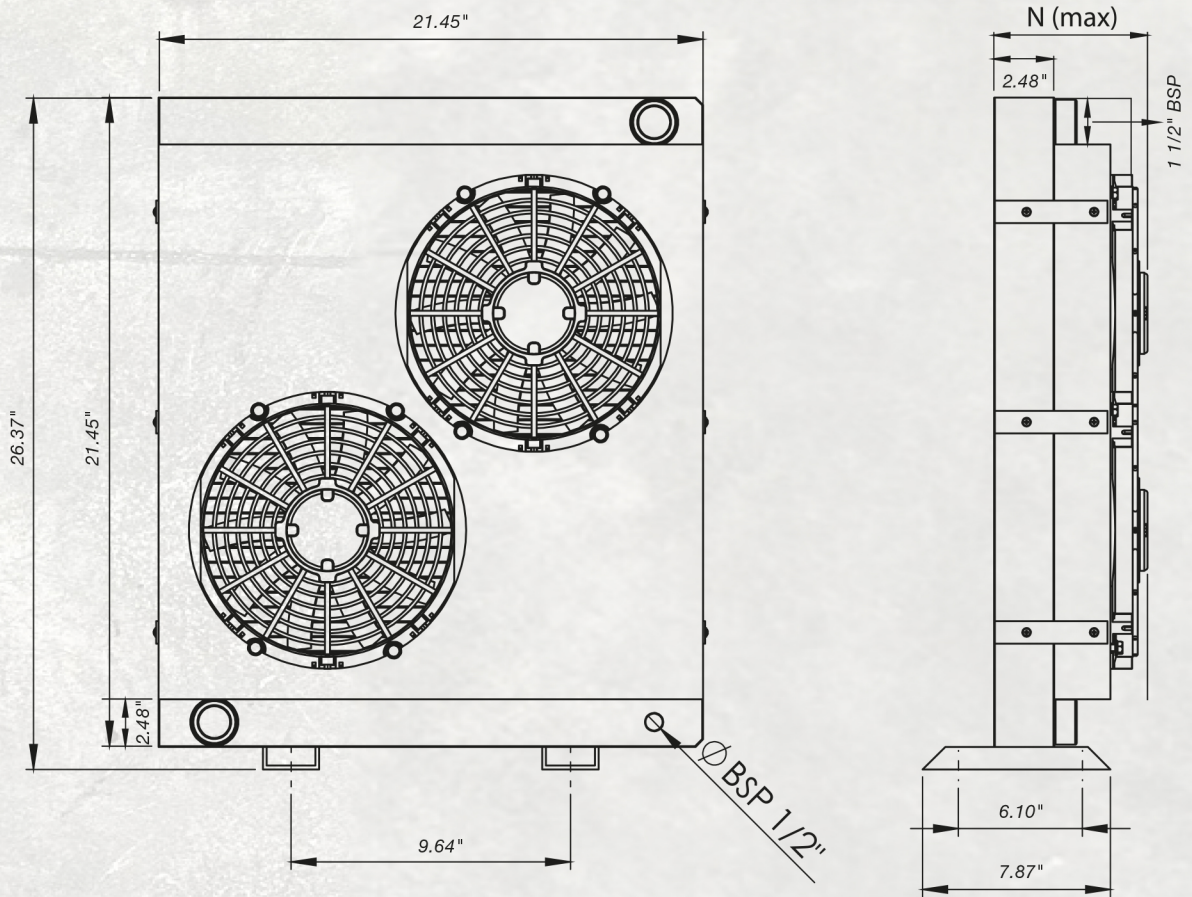

Voltage	Fan Diameter	Fan Speed (RPM)	dB(A) 1M	Power (HP)	Operation Pressure (PSI)	N (Max)
12 & 24	10"	2700	74	0.20	362	7.16"
230 & 400	24.80"	2800	89	0.58	362	9.33"

TCF-60 Hydraulic Cooling Fan

Max Flow (GPM)	Capacity (kcal/h)
58	60000

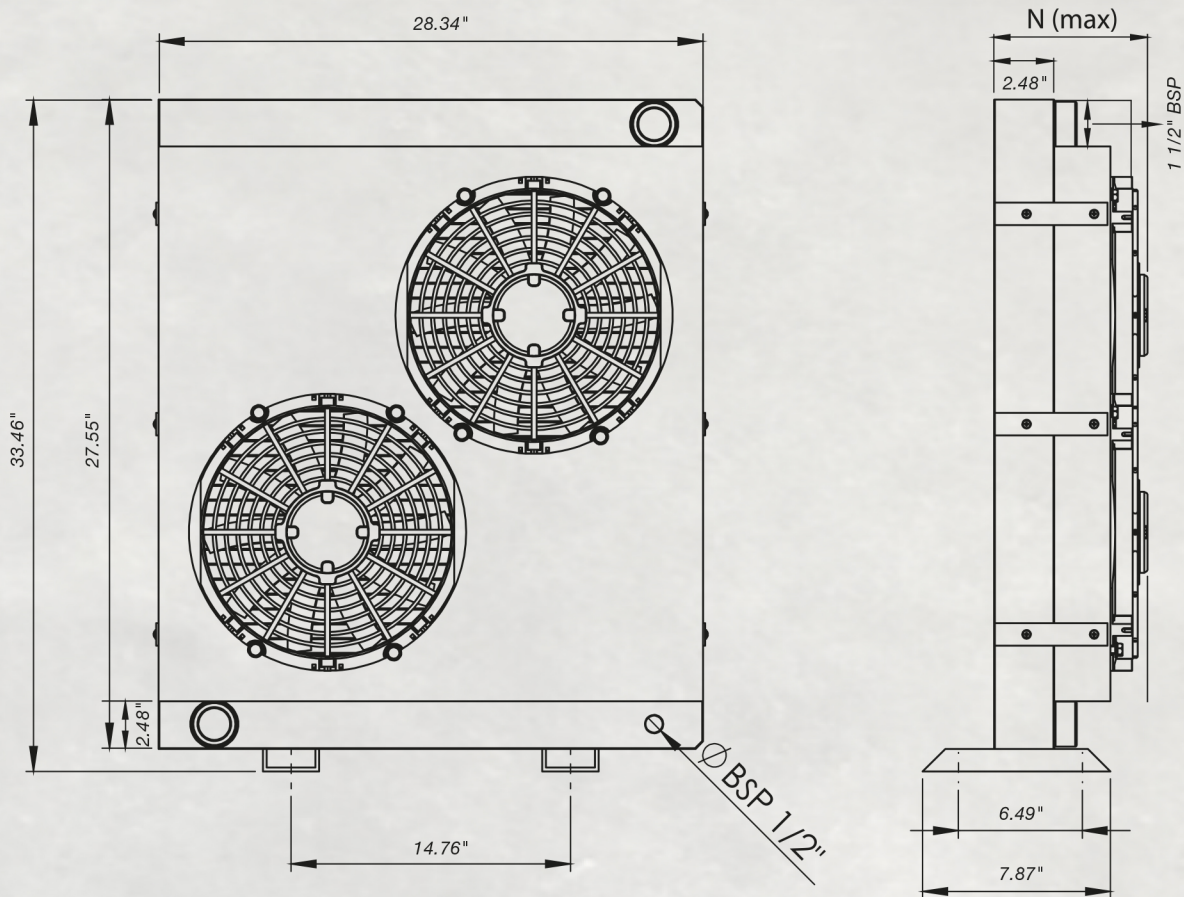

Voltage	Fan Diameter	Fan Speed (RPM)	dB(A) 1M	Power (HP)	Operation Pressure (PSI)	N (Max)
12 & 24	6.10"	2700	74	0.20	362	7.75"
230 & 400	24.80"	2800	98	0.58	362	11.69"

General Information

The G Series is our product line used in all industrial systems. The hydraulic cooling products we offer are manufactured according to high quality standards.

Our products;
In mobile systems,
In fixed unit applications,

They are complete cooling systems for AC-DC uses.

From material supply to production and Strict inspection and surveillance is carried out at every stage, from post-production to quality control processes.

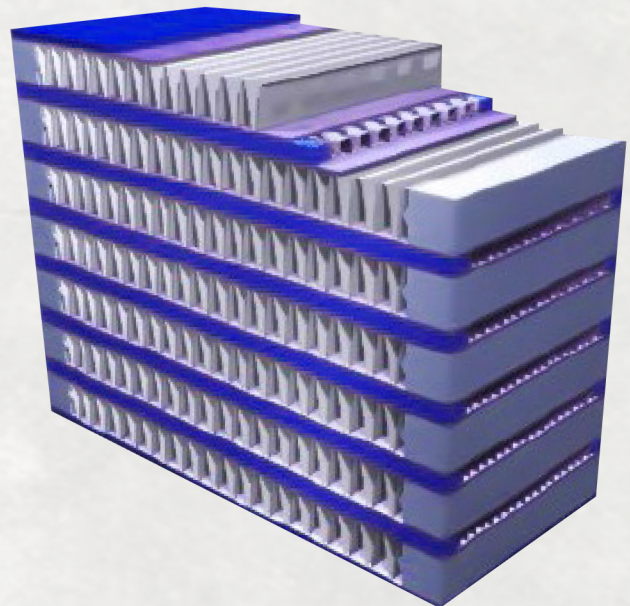
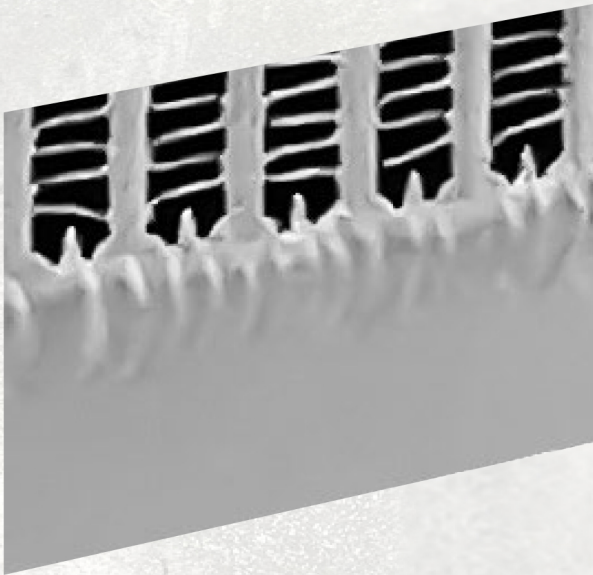

Features

- Test Pressure 30 bar.
- Usage Pressure: 25 bar.
- It is used for cooling of Synthetic, Mineral Oils and some liquids.
- The heat in the fluid is cooled with the help of a fan.
- Bar-P late type cooling pad is used.
- Flexible 6063 aluminum material is used.
- It is designed in accordance with all working conditions.
- It is ready to use and easy to maintain.
- It has high efficiency and low cost.



HYDRAULIC COOLING FAN



🌐 www.toracompany.com
✉ sales@toracompany.com
📍 11417 IL 19, Franklin Park, IL 60131
☎ (630) 785-2410
📱 (331) 688-4947



[toracompany](https://www.toracompany.com)



[tora.company](https://www.toracompany.com)



www.toracompany.com

