

# TCF-05 Hydraulic Cooling Fan

Max Flow (GPM)	Capacity (kcal/h)
21	5500

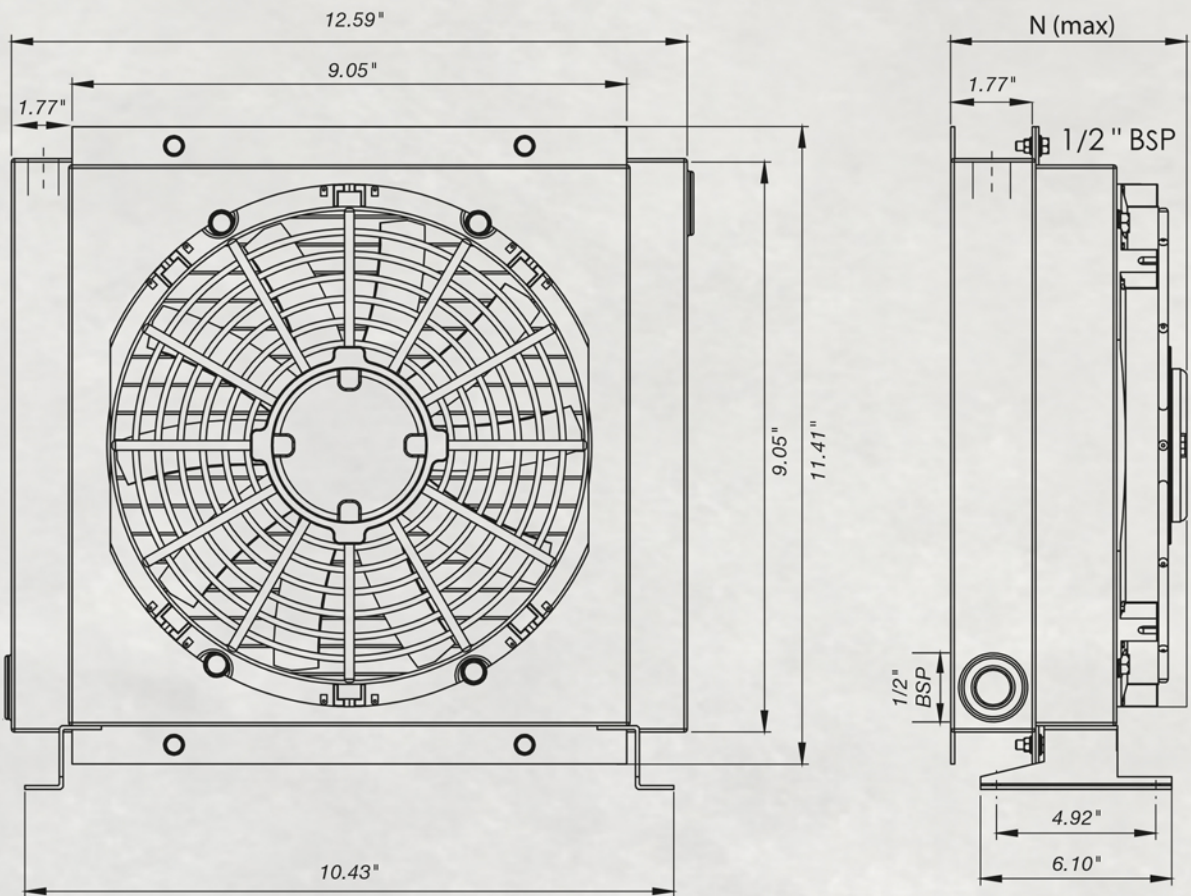

Voltage	Fan Diameter	Fan Speed (RPM)	dB(A) 1M	Power (HP)	Operation Pressure (PSI)	N (Max)
12	7.67"	2700	72	0.12	362	6.77"
24	7.67"	2700	72	0.13	362	6.77"
230 & 400	7.87"	2800	68	0.08	362	8.54"