

THW-55K

Standard

- Cable Tensioner
- Pneumatic Clutch

Hydraulic Inlets

- G 3/4"

Optional

- IP67-IP68
- Roller Fairlead
- Personal Protective Panel
- Double Speed Option

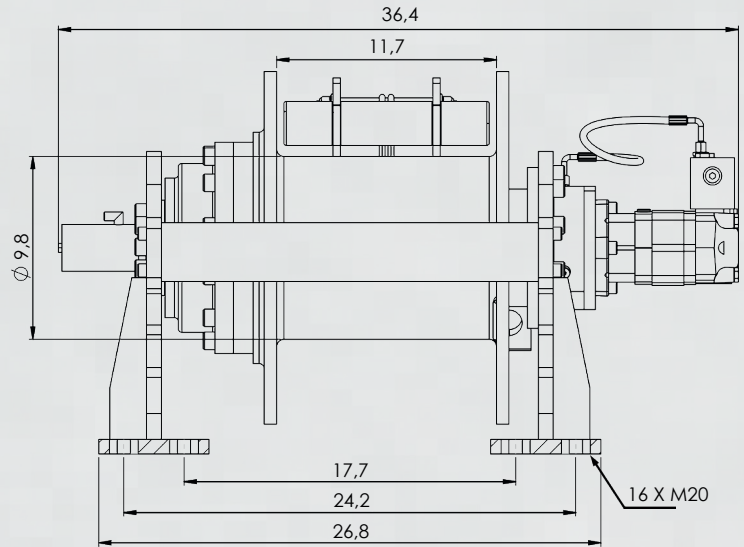
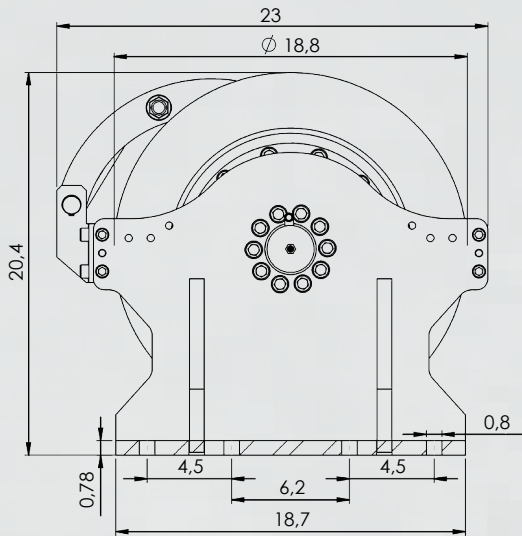
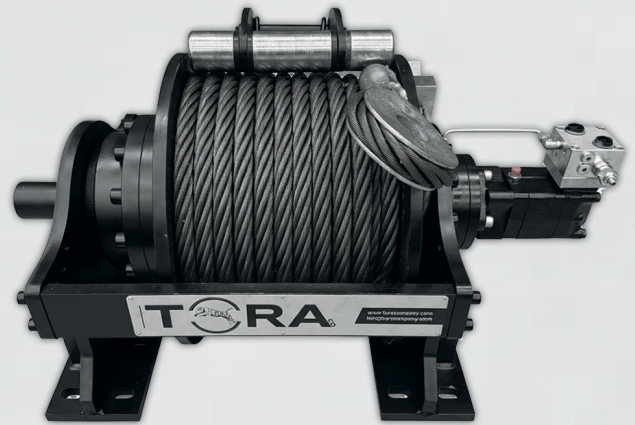

Rope Winding Count	Pulling Capacity lbs	Winding Speed ft-min	Rope Length ft
1	55000	10.4	33.4
2	46788	11.5	70.2
3	40461	12.6	109.9
4	35566	13.4	152.8
5	31708	15.6	196

Maximum Pulling Force	55.000 lbs
Rope Diameter	15/16"
Maximum Pump Flow	19.8 gpm
Maximum Operating Pressure	2755 psi
Recommended Gear Oil Product	140w - (135 fl-oz.)
Weight	650 lbs
Maximum Rope Length	196 ft
Hydromotor	250cc (15.25 ci)
Gear Ratio	74/1

